



# VERTICAL TURBINE PUMPS





## Short Set Vertical Turbine Pumps

- Capacities to 20,000 GPM (4545 m<sup>3</sup>/hr)
- Heads to 1,500 feet (457 m)
- Bowl sizes from 5" to 30"

### Design Features

- Product lube or enclosed lineshaft design.
- Cast or fabricated discharge head and flanged or threaded column assembly.
- 416 SS shafting. Other alloys available.
- Standard cast iron bronze fitted construction. Ductile iron, Ni Al brz, 316 SS or other alloys available.
- Taperlock or keyed impeller design.
- Wear rings optional.
- Packing or mechanical seal design.
- Built-in alignment and simple piping for less costly installation and ease of maintenance/ reduce downtime.

### Services

- Raw Water Intake
- Pumping Station
- Cooling Water
- Commercial/Industrial
- Municipal
- Mining

# Cross Sectional Product Lube

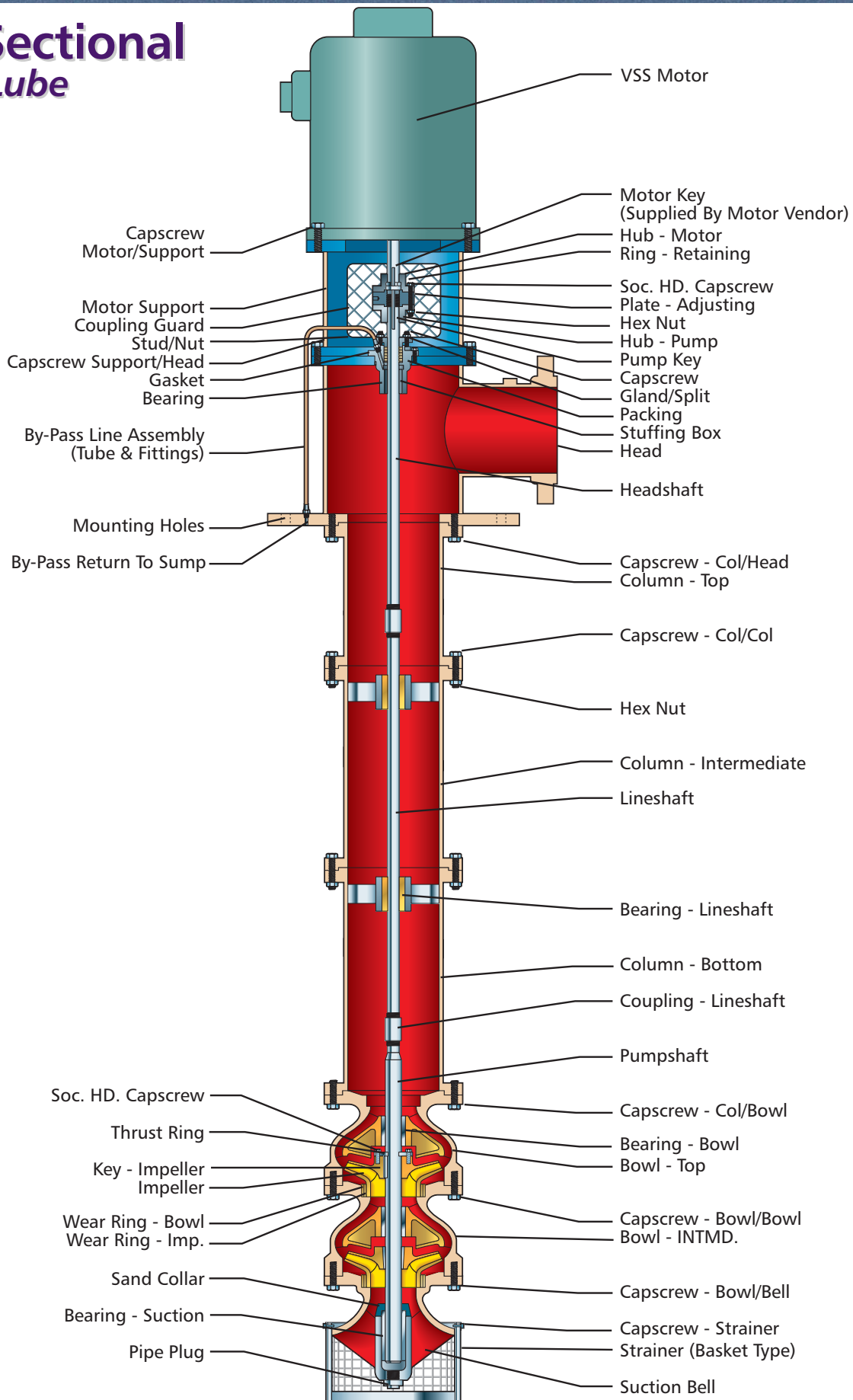



# Pump Bowl Assembly

The bowl assembly is the heart of the vertical turbine pump. The impeller and diffuser type casing are designed to deliver the head and capacity that your system requires in the most efficient way possible. The fact that the vertical turbine pump can be multistaged to allow maximum flexibility both in the initial pump selection and in the event that future system modification requires a change in the pump rating. Submerged impellers allow pump to be started without priming.

## Standard Design Features

- 1. SUCTION BELL** – Allow smooth entry of liquid into impeller eye, minimizes vortex formation.
- 2. SUCTION BELL BEARING** – Provided for shaft stability.
- 3. SAND COLLAR** – Prevents solids from entering suction bearing.
- 4. IMPELLER** – Semi-open or enclosed for appropriate service conditions.
- 5. TAPER LOCK** – Carbon or alloy steel for fastening impellers on 17" and smaller sizes.
- 6. KEYED** – Impeller fastened onto shaft by key and split ring.
- 7. PUMP SHAFT** – Heavy duty 416SS standard, available in 316, 17-4 PH, Monel and other alloys for high strength and corrosion resistance.
- 8. INTERMEDIATE BOWL** – Available in variety of cast materials. Glass lined cast iron standard 6" through 15" sizes.
- 9. STAGES** – Flanged and bolted together for ease of maintenance. Registered fits assure positive alignment.
- 10. SLEEVE TYPE BEARING** – Provided at each stage to assure stable operation away from critical speed.

*In addition to standard features and options shown here, other features are available.*

- A.** Hydraulic balancing of impellers to reduce axial downthrust and achieve longer thrust bearing life.
- B.** Independent flushing of bowl bearings and wear rings for abrasive services.
- C.** Hard facing of shaft journals and bearings to protect against abrasion and increase interval between maintenance periods.
- D.** Interior coating on bowls for improved efficiency.
- E.** Dynamic balancing of impellers.
- F.** Strainer to prevent foreign objects from entering the pump.

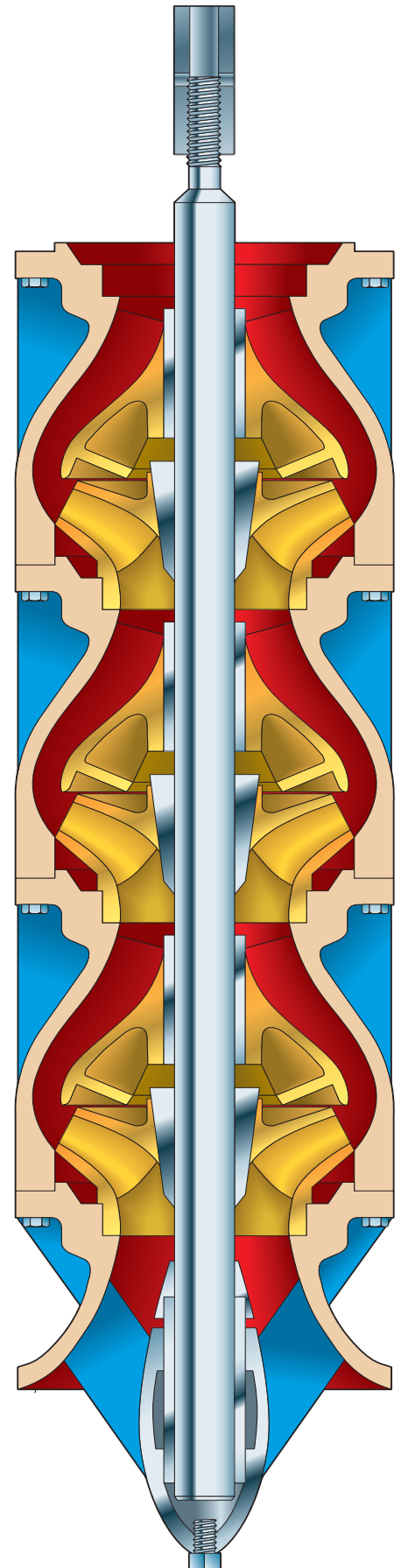

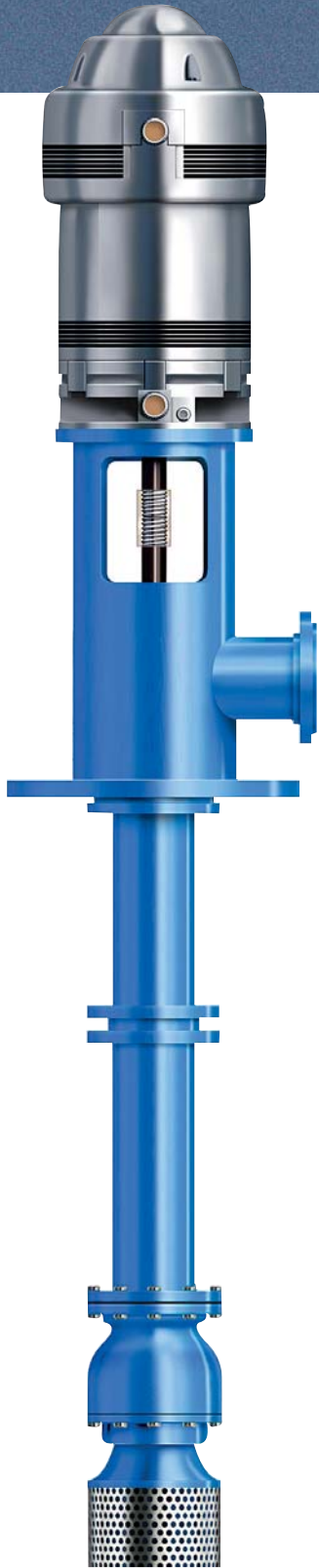

**Type "F"**  
Head

**Type "U"**  
Discharge Located  
Underground

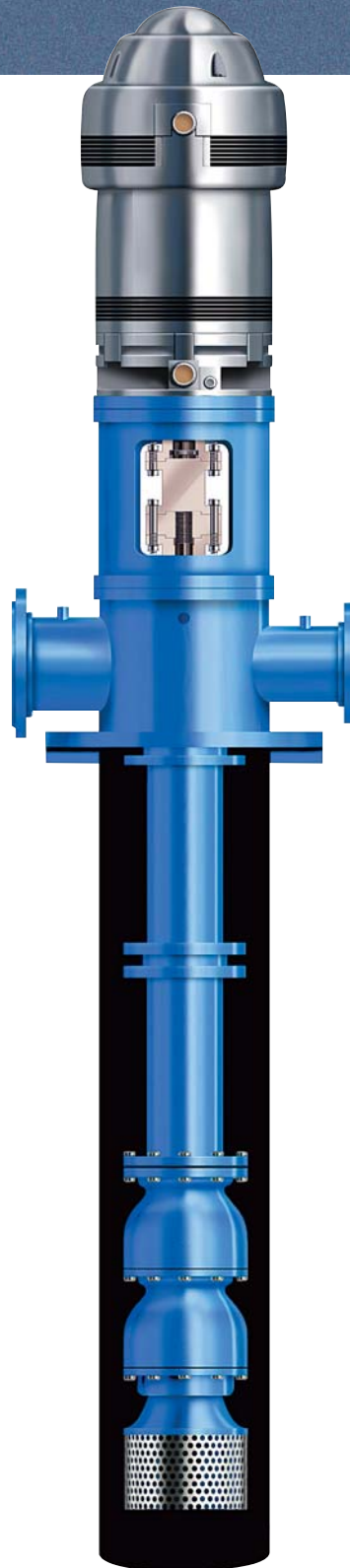

**Type "T"**  
Suction Inlet Located  
in the Head

**Type "L"**  
(Can) Suction Inlet  
Located in the Can



# Pump Bowl Assembly Options

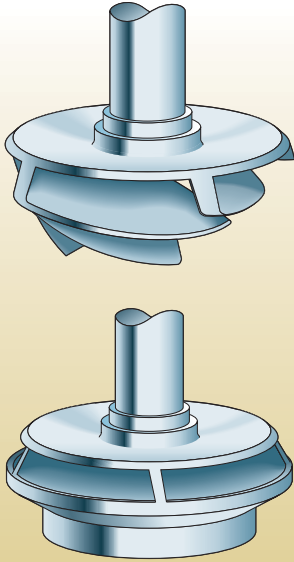

## CHOICE OF SEMI-OPEN OR ENCLOSED IMPELLERS

Available in alloy construction for a wide range of corrosive/ abrasive services.

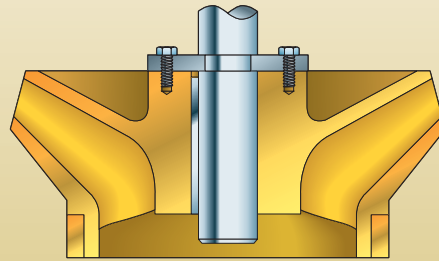

## KEYED IMPELLERS

Keyed impellers are standard on 18" and larger sizes, furnished on all pumps for temperatures above 180° F (82° C). Regardless of size, keyed impellers provide ease of maintenance and positive locking under fluctuating load and temperature conditions.

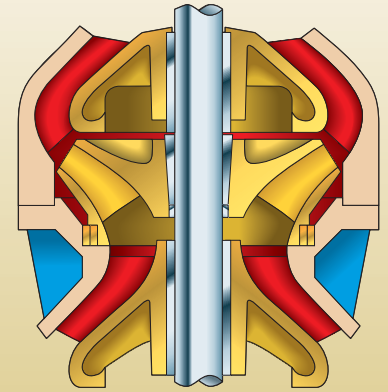

## WEAR RINGS

Available for enclosed impellers and bowls; permits re-establishing initial running clearances and efficiency at lower cost. Hard facing of wear rings can be furnished when solids are present in pumpage.

# Coupling Arrangements

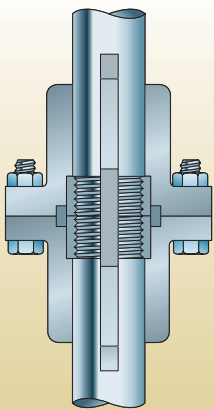

## RIGID FLANGED COUPLING (Type AR)

To couple pump to vertical hollow shaft driver. Impeller adjustment is performed on adjusting nut located on top of motor.

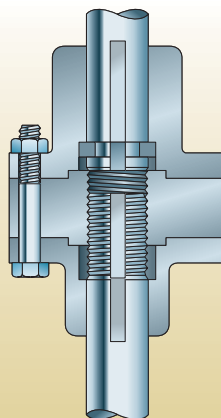

## ADJUSTABLE COUPLING (Type A)

For vertical solid shaft driver. Impeller adjustment made by using adjustable plate in the coupling.

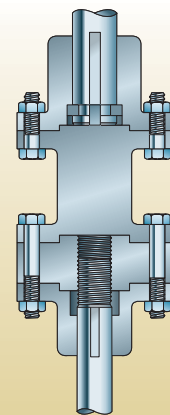

## ADJUSTABLE SPACER COUPLING (Type AS)

Same function as type A coupling with addition of spacer. Spacer may be removed for mechanical seal maintenance without disturbing driver.

# Sealing Flexibility

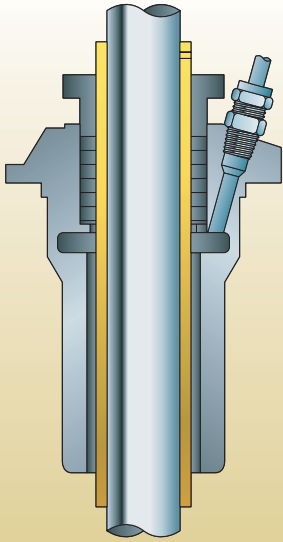

## PACKED BOX WITH SLEEVE OPEN LINESHAFT

Whenever packing, lubrication leakage can be tolerated and the discharge pressure does not exceed 150 psi, a packed box may be used. Optional headshaft sleeve available to protect shaft.

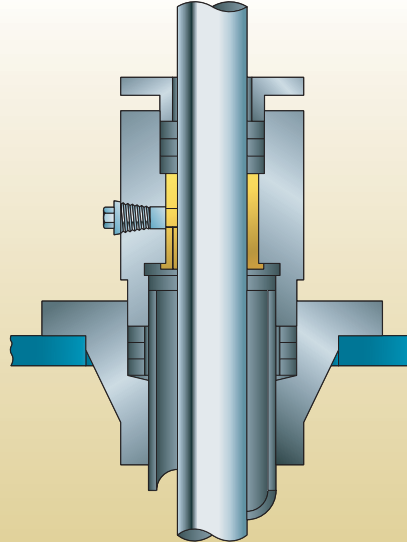

## WATER FLUSH ENCLOSED LINESHAFT

Water flush tube connection is supplied when pressurized water is introduced into the enclosing tube for bearing protection on abrasive services.

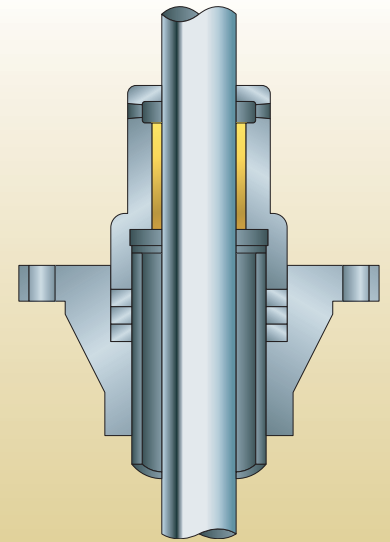

## OIL LUBRICATED ENCLOSED LINESHAFT

Oil lubricated option is recommended when water elevation would cause the upper lineshaft bearings to run without lubrication during startup. Oil is fed through tapped opening and allowed to gravitate down enclosing tube lubricating bearings.

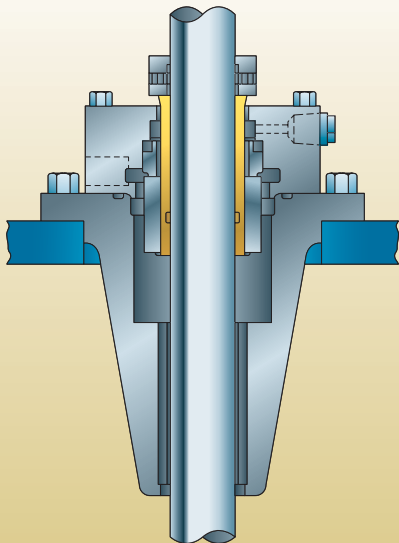

## SINGLE SEAL

Most popular method — used for low to medium pressures. Cartridge style for ease of installation and maintenance.

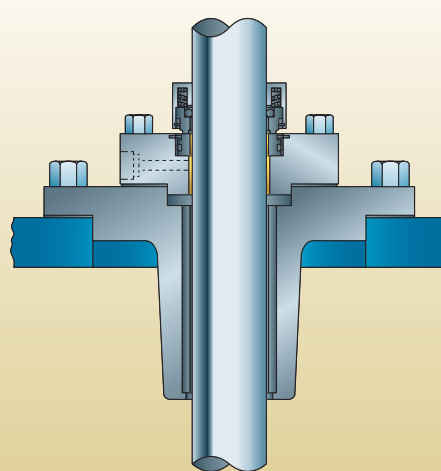

## OUTSIDE MOUNTED SEALS

Provides a method of no-leak sealing for low pressure and water application.

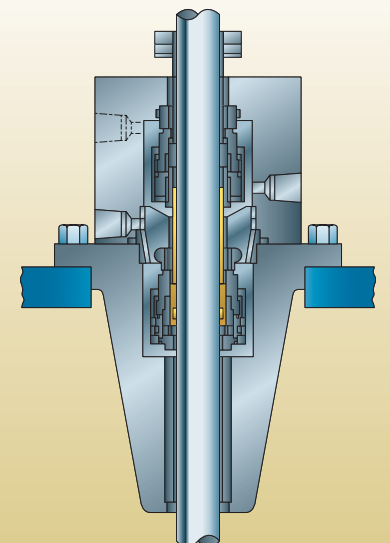

## TANDEM SEALS

Two seals mounted in-line. Chamber between seals can be filled with a buffer liquid and may be fitted with a pressure sensitive annunciating device for safety.

# SUBMERSIBLE

## Applications

Goolds Pumps combines the hydraulic engineering of turbine pumps matched to the hi-tech design of electric submersible motors.

## Features

### 1 Discharge Pipe

Properly sized for optimum water velocities to insure peak hydraulic performance.

### 2 Discharge Bowl

Several discharge sizes available for NPT or flanged pipe.

### 3 Discharge Bearing

Extra long top protected bronze bearing insures positive shaft alignment and stabilization for extended life.

### 4 Intermediate Bowl

Glass lined cast iron standard 6" through 15" size for maximum efficiency and abrasion resistance.

### 5 Impellers

Designed for maximum efficiency with wide range hydraulic coverage. Precision balanced for smooth operation.

### 6 Upthrust Washer

Designed for extra margin of safety against possible momentary upthrust occurring at startup.

### 7 Intermediate Bowl Bearings

Reliable long life bronze or rubber bearing.

### 8 Taper Lock

Accurately machined to insure positive locking of impeller to pump shaft.

### 9 Pump Shaft

100,000 PSI high tensile stainless steel provides strength and excellent corrosion resistance. Ground and polished for smooth bearing surface.

### 10 Suction Inlet

Contoured for smooth flow entrance. Protected by an oversized stainless steel strainer to prevent entrance of damaging solids.

### 11 Suction Adapter

Ductile iron provides for increased strength and positive motor alignment. Open area permits easy access to pump/motor coupling.

### 12 Pump/Motor Coupling

Large stainless steel coupling accurately machined for perfect alignment, balance and power transmission.

Submersible pumps and motors provide an extensive list of options versus other deep well pumping equipment systems. Advanced engineering designs and experience assure units for long term pumping service. Water well applications provide the perfect opportunity to evaluate features and benefits of submersible equipment.

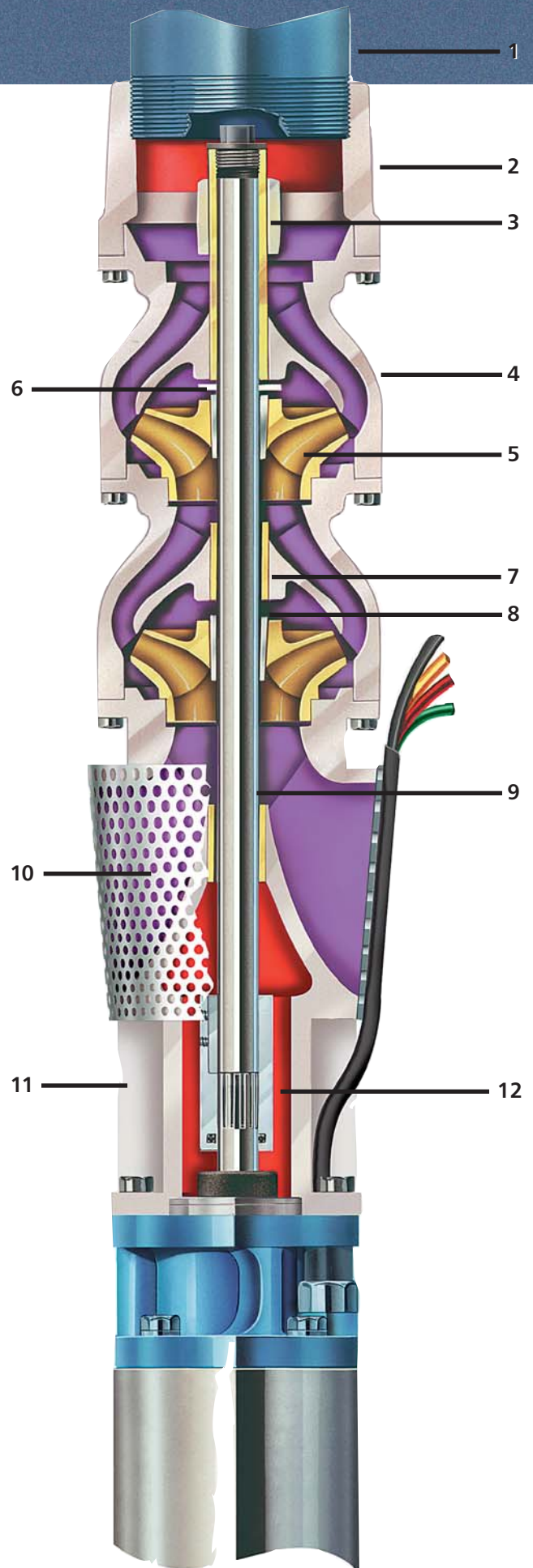

## Hermetically Sealed Type

A Hermetically Sealed Type motor utilizes windings of standard construction and insulation thickness. The windings are encased and Hermetically Sealed within the external shell casing on the outside and an internal tube or liner inside the bore. The Hermetically Sealed enclosure eliminates the possibility of water leakage into the winding. The liquid medium circulates between the rotor and stator liner providing lubrication and cooling to the bearings.

## Wet Winding Type

A Wet Winding Type motor is one in which the motor windings are in direct contact with a liquid medium. The medium is clean, clear water. A pressure balancing system prevents exchange of the motor liquid medium and well water due to thermal expansion and contraction when the motor is operating. The liquid medium fills the inside of the motor and surrounds both the stator windings and the rotor. A completely water proof insulation is used on the magnet wire used for the stator windings. The liquid medium inside the motor air gap and coils acts as a heat transfer device by circulating through the windings and transferring heat to the external casing. Dissipation of this heat occurs as the well water flows at a required velocity over the external case. As is the case in all submersible type motors, the internal liquid medium is also used for bearing lubrication.



## Submersible Options

Goulds Pumps can provide several options in pump and motor combinations to meet the exacting conditions of your applications:

- High temperature wells
- High horsepower, limited well diameters
- Motor sensing devices
- Water level indicators
- Special materials
- Special voltage motors

Consult Goulds Pumps Turbine Customer Service Dept. for details.

## Submersible Accessories:

- Valves
  - Check Valves
  - Flow Control
  - Gate Valves
  - Ball Valves
- Electrical Panels
  - Furnas Panels
  - V.F.D. Drivers
- Pitless Adapters
- Wire
  - 12 to 0000
- Heat Shrinks
- Splice Kits
- Tanks
- Well Heads
  - Submersible Discharge Head
- Torque Arrestors
- Gauges
- Motor Shrouds

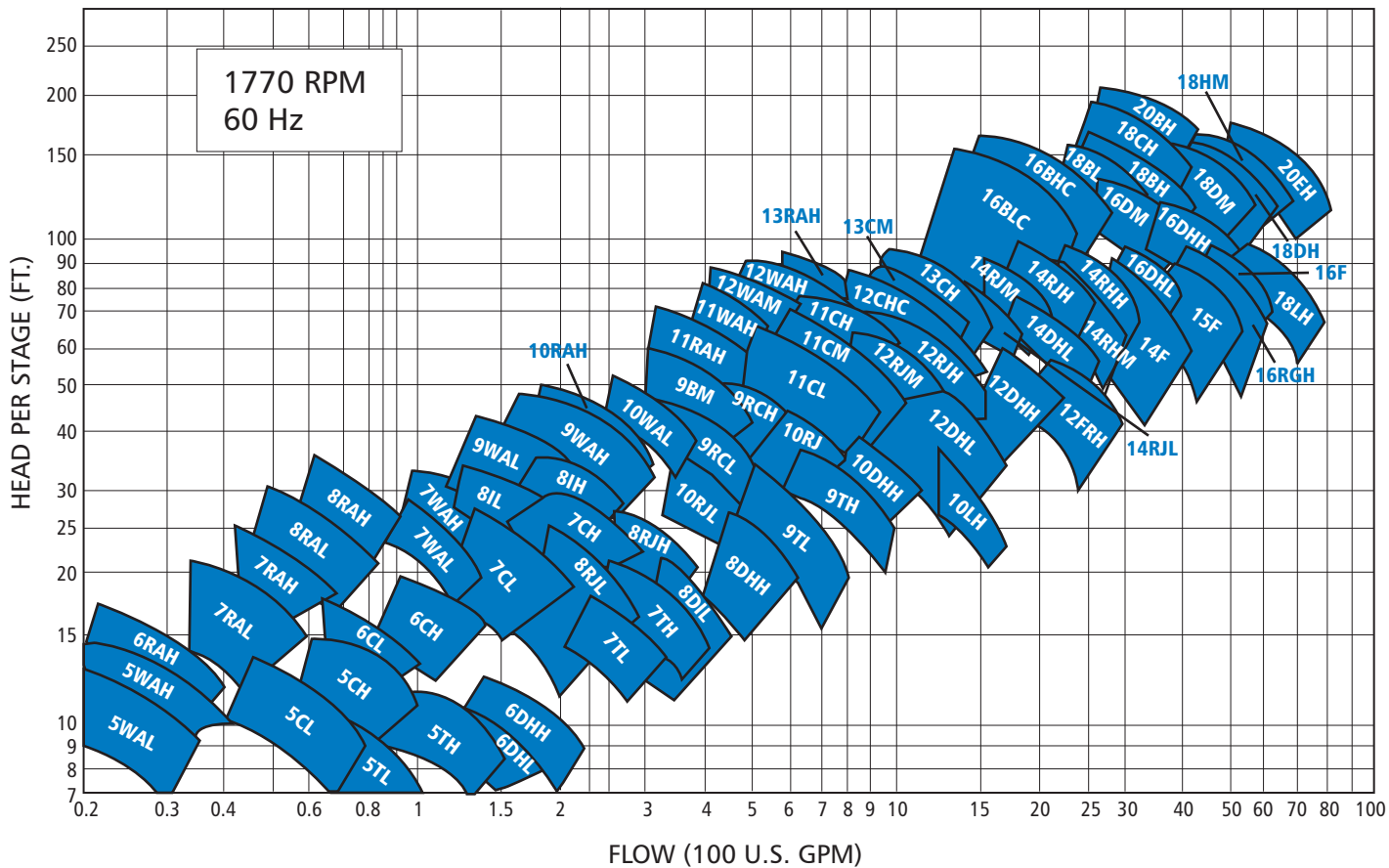
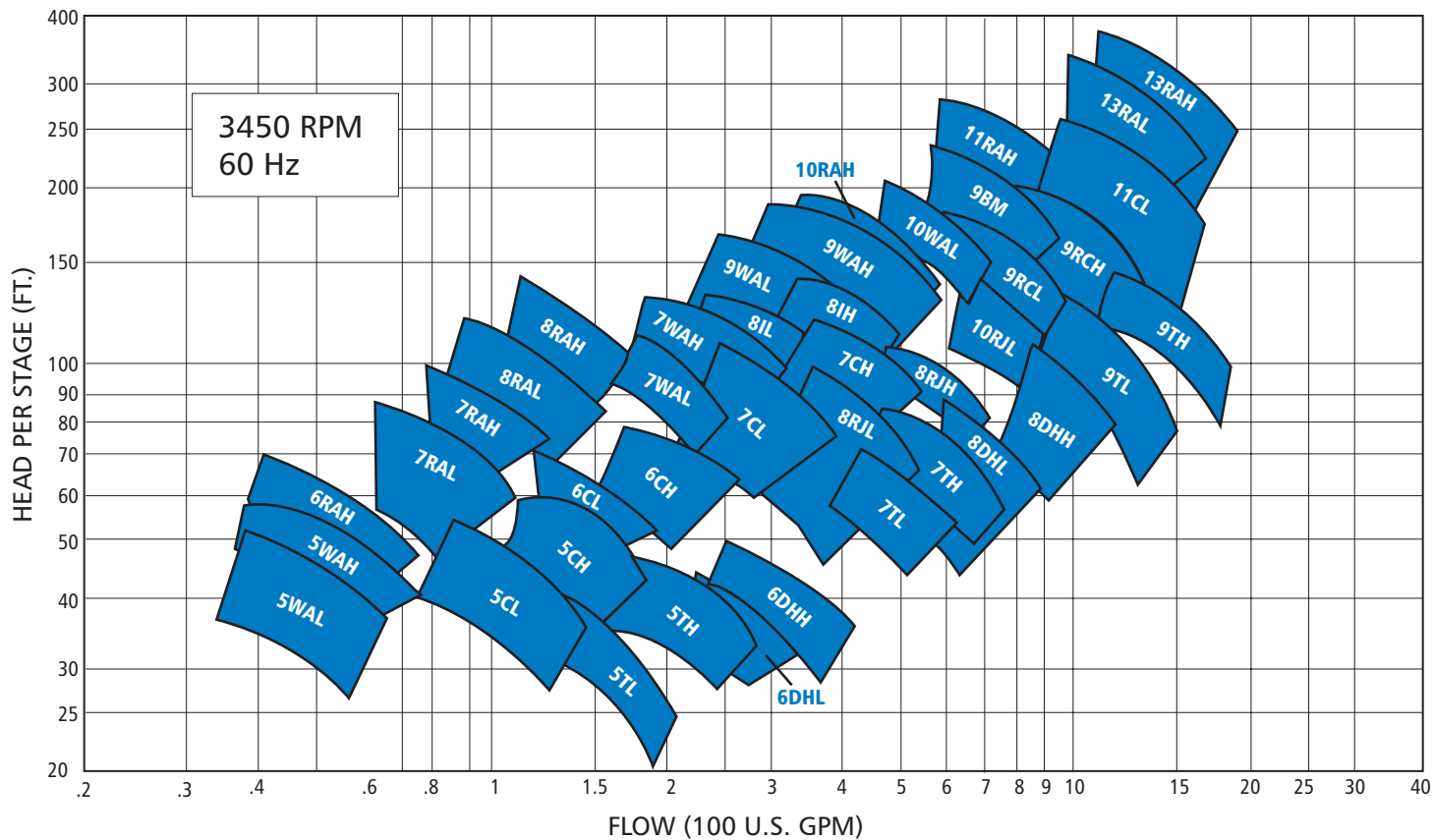

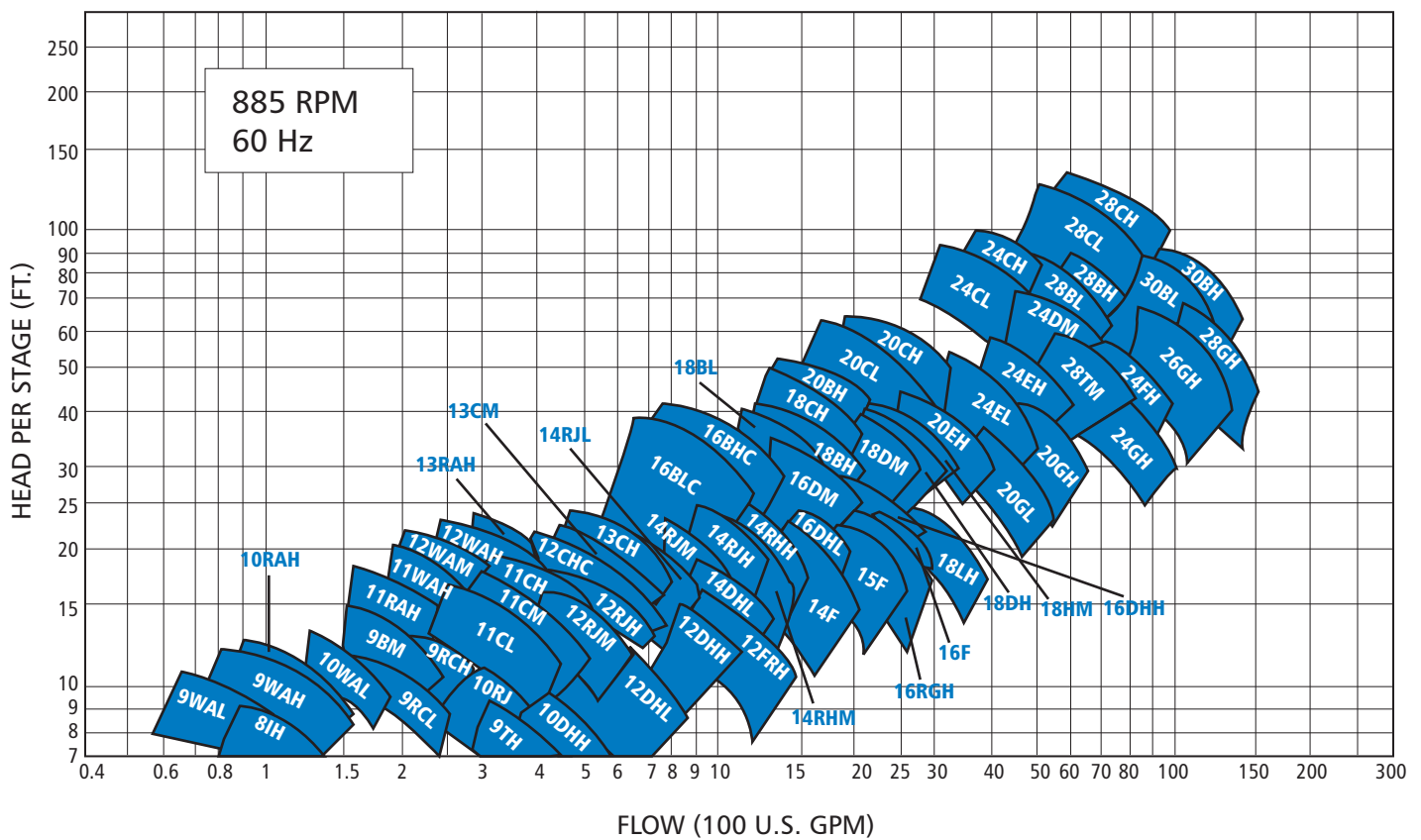
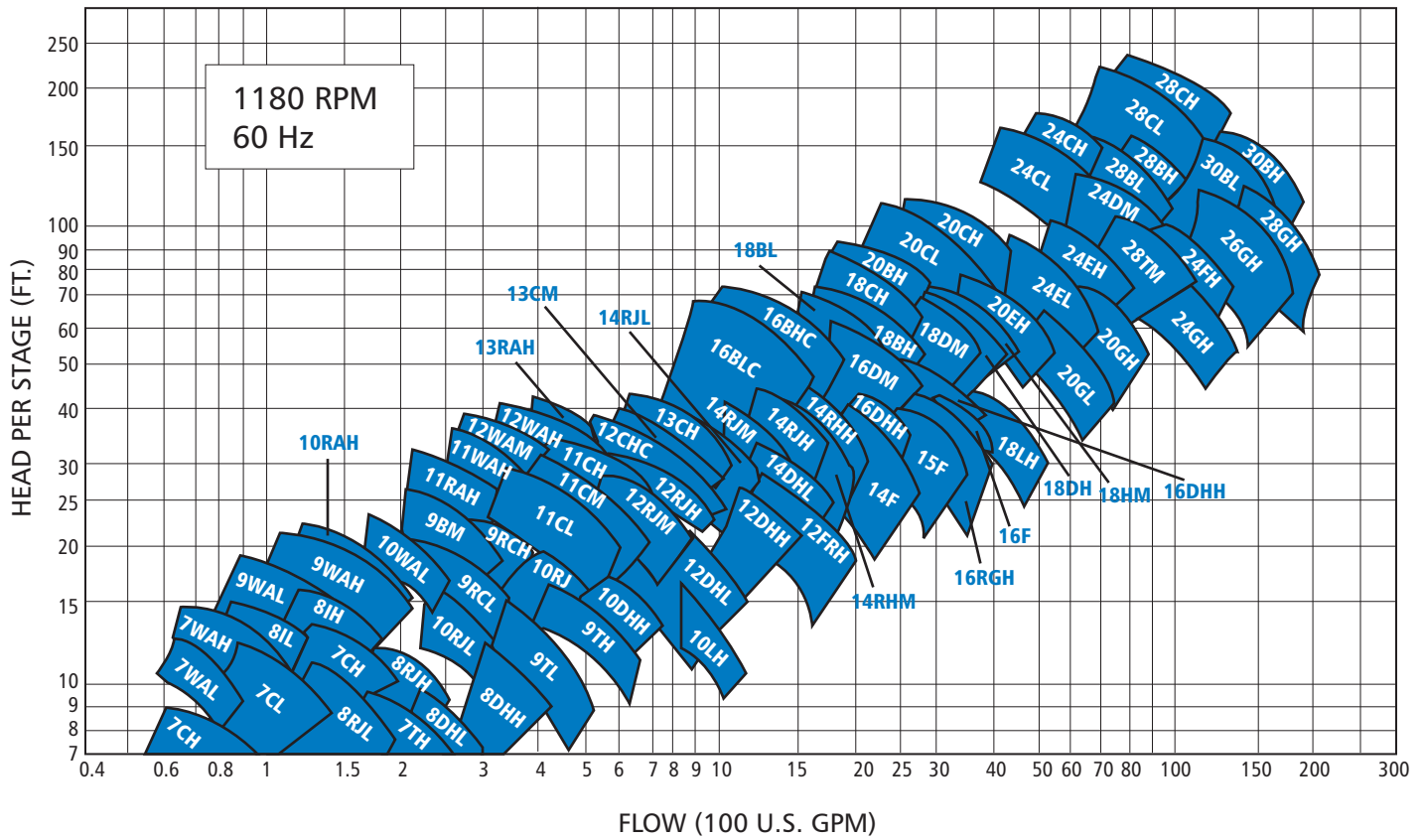



## NOTES

---

## NOTES

---

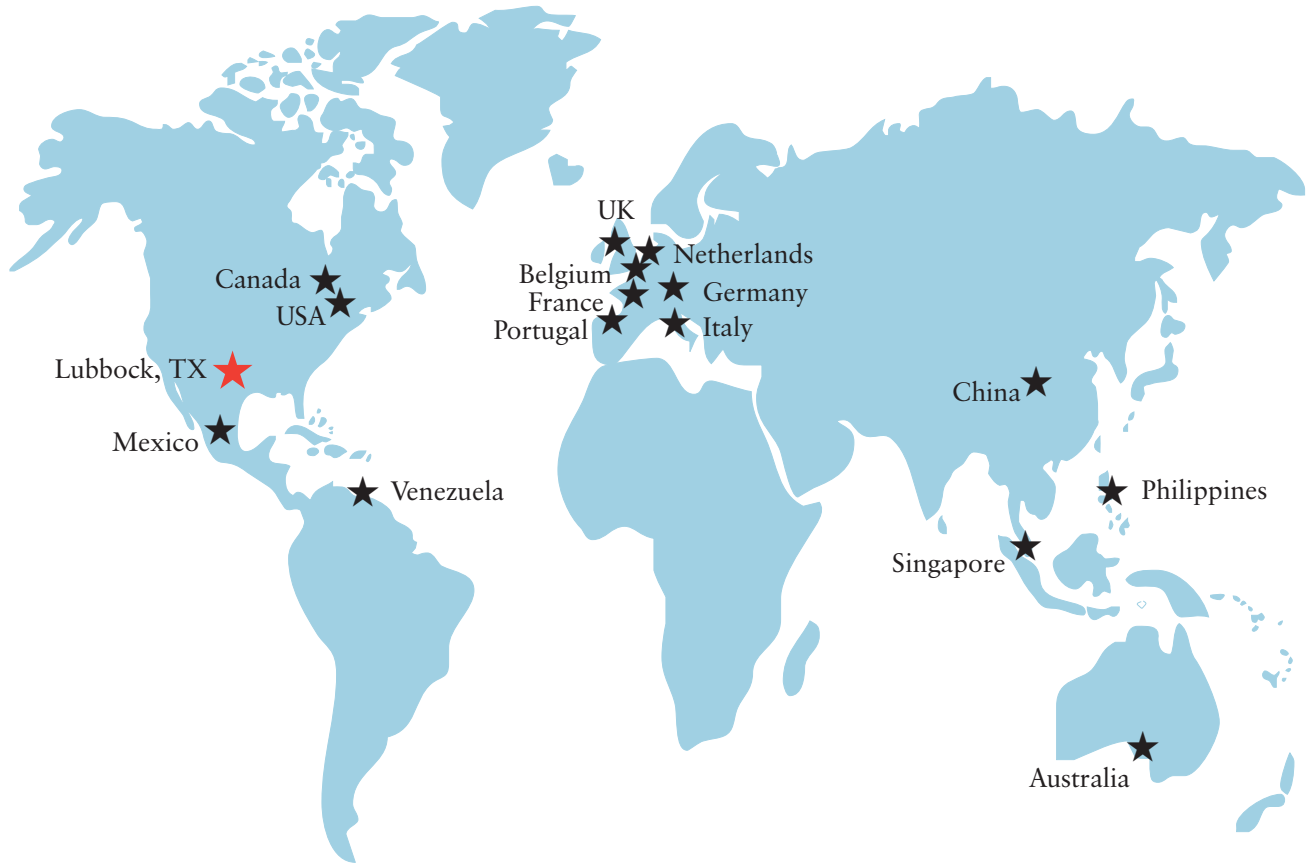

Goulds Pumps, headquartered in Seneca Falls, New York, designs, manufactures and services pumps, motors and accessories for industrial, agricultural, municipal, commercial and residential markets. Goulds Pumps was founded in 1848 and remains an acknowledged industry leader. Our sales offices and manufacturing facilities are located worldwide.

Goulds Pumps is a brand of ITT Water Technology, Inc. – a subsidiary of ITT Industries, Inc., the world's largest and premier pump manufacturer, and offers the most complete range of pumps available.

Goulds Pumps...Leading The Way Since 1848.

<b>Turbine Distribution Centers:</b>	<b>Phone</b>	<b>Fax</b>
<b>LUBBOCK, TX</b> P.O. Box 5487, Lubbock, TX 79408	<b>1-806-763-7867</b>	<b>1-800-453-4749</b>
<b>MEMPHIS, TN</b> 5815 Shelby Drive, Memphis, TN 38141	<b>1-901-375-9965</b>	<b>1-800-453-4745</b>
<b>ORLANDO, FL</b> 1150 Emma Oaks Trail, Suite 150, Lake Mary, FL 32746	<b>1-407-829-7724</b>	<b>1-800-453-4748</b>
<b>FRESNO, CA</b> 3878 S. Willow Ave., #104, Fresno, CA 93725	<b>1-559-265-4730</b>	<b>1-800-453-7523</b>

<b>Specifications &amp; Special Projects:</b>		
<b>LUBBOCK CUSTOMER SERVICE CENTER</b>	<b>1-806-763-7867</b>	<b>1-800-453-4749</b>

Visit our website at [www.goulds.com](http://www.goulds.com)