

ITT

Commercial Water

Goulds Pumps

SSV G&L Series
Repair Parts



Goulds Pumps is a brand of ITT Water Technology, Inc.
- a subsidiary of ITT Industries, Inc.

www.goulds.com

Engineered for life

TABLE OF CONTENTS

SSV MULTI-STAGE

SSV Product Line Numbering System	3-4
Impellers and Intermediate bearings layout	5
Bearings Position.....	6
Coupling table.....	7
1SV and 2SV Sectional view of pump.....	8
1SV and 2SV List of repair parts	9
3SV and 4SV Sectional view of pump.....	10
3SV and 4SV List of repair parts	11
33SV and 46SV Sectional view of pump.....	12
33SV and 46SV List of repair parts	13
66SV and 92SV Sectional view of pump.....	14
66SV and 92SV List of repair parts	15
Horizontal Mounting options.....	16
Victaulic connections	16
Motor Adapter and Adapter Ring table.....	17
Obsolete 5SV and 6SV Information	18-22

1 – 4SV PRODUCT LINE NUMBERING SYSTEM

The various versions of the SSV line are identified by a product code number on the pump label. The number is also the catalog number for the pump. The meaning of each digit in the product code is shown below.

2 SV A 1 D 2 B 0 H

OPTIONS

H = Horizontal Mounting AQ = Staging for Aquavar Units
 Vic = Victaulic Connections

MECHANICAL SEAL OPTIONS

Code No.	Rotary	Stationary	Elasto- mers	1SV		2SV		3SV		4SV		5SV / 6SV	
				60 Hz (2-16 stg.)	60 Hz (18-22 stg.)	60 Hz (2-15 stg.)	60 Hz (16-22 stg.)	60 Hz (2-13 stg.)	60 Hz (14-16 stg.)	60 Hz (2-10 stg.)	60 Hz (12 stg.)	60 Hz (all)	DPS (all)
				50 Hz (all)	DPS (all)	50 Hz (all)	DPS (all)	50 Hz (all)	DPS (all)	50 Hz (all)	DPS (all)	50 Hz (all)	
0	High Temp Carbon	Silicon Carbide	Viton	10K93	10K113	10K93	10K113	10K94	10K114	10K94	10K114	10K95	10K95
2	Silicon Carbide		EPR	10K140	10K176	10K140	10K176	10K146	10K177	10K146	10K177	10K147	10K147
4	Silicon Carbide		Viton	10K99	10K178	10K99	10K178	10K100	10K179	10K100	10K179	10K101	10K101
6	High Temp Carbon		EPR	10K96	10K115	10K96	10K115	10K97	10K116	10K97	10K116	10K98	10K98

NUMBER OF STAGES

F = 6 L = 11 R = 16 Z = 24
 B = 2 G = 7 M = 12 S = 17
 C = 3 H = 8 N = 13 T = 18
 D = 4 J = 9 P = 14 V = 20
 E = 5 K = 10 Q = 15 X = 22

DRIVER

1 = 1PH, ODP 4 = 1 PH, TEFC 7 = 3 PH, XP 0 = 1 PH, XP
 2 = 3 PH, ODP 5 = 3 PH, TEFC 8 = 575 V, XP
 3 = 575 V, ODP 6 = 575 V, TEFC 9 = 3 PH, TEFC Premium Efficiency

HP RATING

C = 1/2 HP F = 1 1/2 HP J = 5 HP M = 15 HP
 D = 3/4 HP G = 2 HP K = 7 1/2 HP N = 20 HP
 E = 1 HP H = 3 HP L = 10 HP P = 25 HP

HERTZ/RPM

1 = 60 HZ, 3450 RPM, 2 pole 5 = 60 HZ, 3500 RPM, 220-380V, D.O.L.
 2 = 60 HZ, 2900 RPM, 2 pole 6 = 60 HZ, 3500 RPM, 380V, V-Delta
 3 = 60 HZ, 3500 RPM, 380V 7 = 60 HZ, 1750 RPM, 208-230/460V
 4 = 50 HZ, 2900 RPM, 460V

MATERIAL AND SUCTION/DISCHARGE

A = 304 Stainless Steel, in-line NPT threaded oval flange connections (1-3 SV only)
 B = 304 Stainless Steel, in-line ANSI flange
 C = 304 Stainless Steel, top/bottom ANSI flange connections
 D = 316 Stainless Steel, in-line ANSI flange

PRODUCT LINE

Stainless Steel Vertical

NOMINAL FLOW

1 = 15 GPM 3 = 55 GPM
 2 = 28 GPM 4 = 86 GPM

The various versions of the SSV line are identified by a product code number on the pump label. This number is also the catalog number for the pump. The meaning of each digit in the product code number is shown below.

Note: Not all combinations are possible. Consult your G&L distributor.

EXAMPLE PRODUCT CODE

33 SV B G 1 2 R 6 T A H

Pump Options (optional):

H = Horizontal mounting
 Q = 1.0 Service Factor Version (AQ) D = High Pressure Pump (> 25 bar)

Seal Options:

	Code No.	Rotary	Stationary	Elastomers	Part Number			
					33SV	46SV	66SV	92SV
Mechanical Seal	A	Silicon Carbide	Carbon	Viton	10L38			
	B			EPR	10L40			
	C		Silicon Carbide	Viton	10L39			
				EPR	10L37			
Cartridge Seal	L		Carbon	Viton	10K163			
	P		Silicon Carbide	EPR	10K166			

Motor Enclosure:

D = ODP T = TEFC
 X = Explosion Proof P = TEFC Premium Effy

Motor Voltage:

1 = 115/230 2 = 230 only 3 = 230/460 4 = 460 only
 5 = 575 6 = 208-230/460 7 = 200 8 = 190/380

HP Rating:

G = 2 HP M = 15 HP S = 50 HP
 H = 3 HP N = 20 HP T = 60 HP
 J = 5 HP P = 25 HP U = 75 HP
 K = 7½ HP Q = 30 HP
 L = 10 HP R = 40 HP

Motor Hertz/Speed/Phase:

1 = 60 Hz/3500/1 2 = 60 Hz/3500/3 3 = 60 Hz/1750/1 4 = 60 Hz/1750/3
 5 = 50 Hz/2900/1 6 = 50 Hz/2900/3 7 = 50 Hz/1450/1 8 = 50 Hz/1450/3
 9 = 60 Hz/Variable/3

Number of Reduced Diameter Impellers (0, 1, 2)

Bowls/Stages:

A = 1 E = 5 J = 9
 B = 2 F = 6 K = 10
 C = 3 G = 7
 D = 4 H = 8

Flange Orientation:

B = Cast Iron/316 stainless steel, in-line ANSI flange
 D = 316 stainless steel, in-line ANSI flange

Product Line:

Stainless Vertical Multi-Stage

Nominal Flow:

33 = 150 GPM 66 = 350 GPM
 46 = 225 GPM 92 = 450 GPM

1 – 4SV IMPELLERS AND INTERMEDIATE BEARINGS LAYOUT

Number of Stages	Number of Bearings	1SV Number of Impellers in Location					Number of Bearings	2SV Number of Impellers in Location					Number of Bearings	3SV Number of Impellers in Location				Number of Bearings	4SV Number of Impellers in Location				
		A	B	C	D	E		A	B	C	D	E		A	B	C	D		A	B	C	D	
2	1	1	1				1	1	1				1	1	1				1	1	1		
3	1	1	2				1	1	2				1	1	2				1	1	1		
4	1	2	2				1	2	2				1	2	2				1	1	1		
5	1	2	3				1	2	3				1	2	3				1	1	1		
6	1	2	4				1	2	4				1	2	4				1	1	1		
7	1	2	5				1	2	5				1	2	5				1	1	1		
8	1	2	6				1	2	6				2	2	3	3			2	2	3	3	
9	2	2	4	3			2	2	4	3			2	2	4	3							
10													2	2	4	4			2	2	4	4	
11	2	2	5	4			2	2	5	4			2	2	5	4							
12	2	2	5	5									2	2	5	5			2	2	5	5	
13	2	2	6	5			2	2	6	5			3	2	3	4	4						
14	2	2	6	6			2	6	6	6			3	2	4	4	4		3	2	4	4	4
15	2	2	7	6			2	2	7	6								3	2	4	4	5	
16	2	2	7	7			2	2	7	7			3	2	4	5	5						
18	3	2	5	6	5		3	2	5	6	5												
20	3	2	6	6	6		3	2	6	6	6												
22	4	7	5	5	5	5	4	2	5	5	5	5											
24	4	2	6	6	5	5	4	2	6	6	5	5											

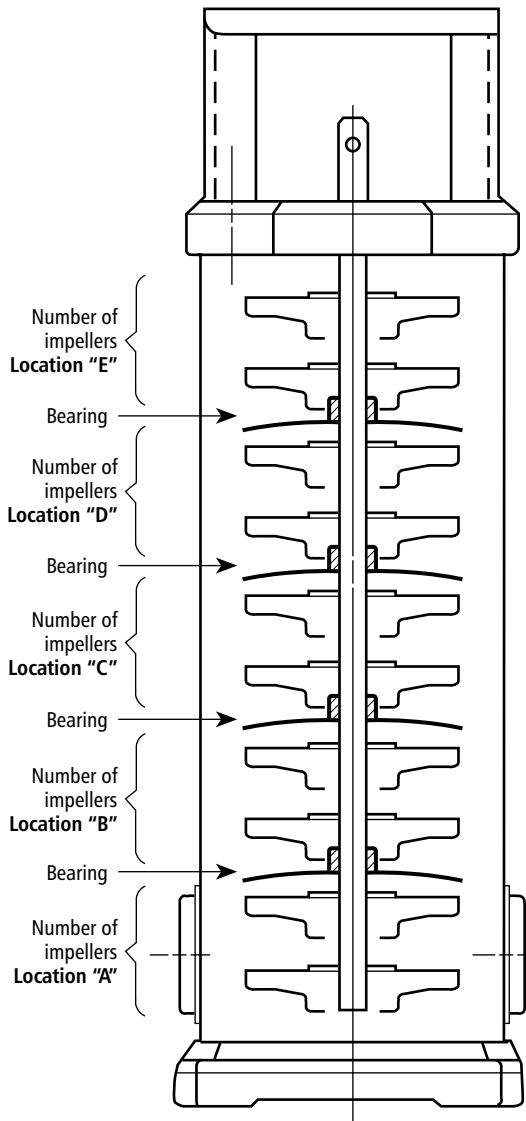

The chart on this page is used to locate the correct bearing position(s) on the impeller stack of the SSV series pumps. To use this chart:

1. Locate the number of stages in the left hand column of the above chart which corresponds to the pump you are working on.
2. Follow the selected row across to the pump size (1SV etc).
3. Under the "A" location, you will find the number of impellers on the bottom of the stack which come before the first bearing.
4. Under the "B" location, you will find the number of impellers which go above the first bearing and below the second bearing (if there is one).
5. Under the "C" location, you will find the number of impellers which go above the second bearing and below the third bearing (if there is one).
6. Under the "D" location, you will find the number of impellers which go above the third bearing.
6. Under the "E" location, you will find the number of impellers which go above the third bearing.

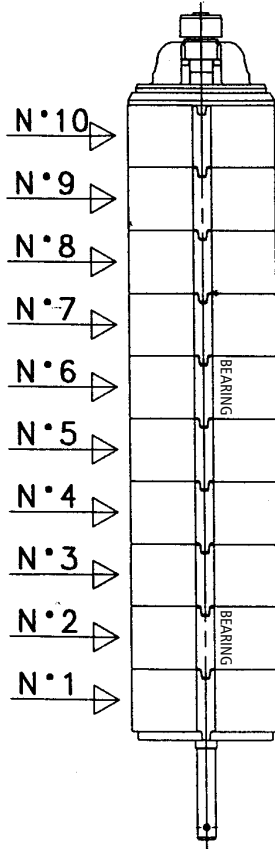

SV 33 – 46

Number of Stages	Bearing Position	Number of Diffuser with Bearing
1		
2		
3		
4		
5	N°2	1
6	N°2	
7	N°3	
8	N°4	
9	N°5	
10	N°2 and N°6	2

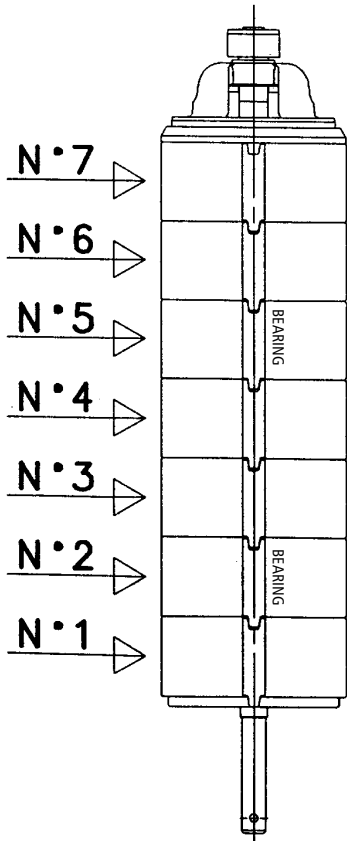

SV 66 – 92

Number of Stages	Bearing Position	Number of Diffuser with Bearing
1		
2		
3		
4	N°2	1
5	N°2	
6	N°3	

COUPLING TABLE

Item No.	Pump Size			Number of Stages																			
				2	3	4	5	6	7	8	9	10	11	12	13	14	15	16	18	20	22	24	
118	1SV	60 Hz	TEFC	4L188											4L189								
			ODP	4L188											4L189								
		50 Hz	TEFC	4L188											4L188								
			ODP	4L188												4L188							
	2SV	60 Hz	TEFC	4L188																			
			ODP	4L188																			
		50 Hz	TEFC	4L188																			
			ODP	4L188																			4L189
	3SV	60 Hz	TEFC	4L190			4L191			4L192			4L193										
			ODP	4L190			4L191			4L192			4L193										
		50 Hz	TEFC	4L190			4L191			4L192			4L193			4L192			4L192				
			ODP	4L190			4L191			4L192			4L193			4L192			4L193				
	4SV	60 Hz	TEFC	4L191			4L192			4L193													
			ODP	4L191			4L192			4L193													
		50 Hz	TEFC	4L191			4L192			4L193			4L193			4L193							
			ODP	4L191			4L192			4L193			4L193			4L193							
	5SV (obsolete)	60 Hz	TEFC	4L312			4L313			4L314													
			ODP	4L312			4L313			4L314													
		50 Hz	TEFC	4L312			4L313			4L314													
			ODP	4L312			4L313			4L314													
	6SV (obsolete)	60 Hz	TEFC	4L312			4L313			4L314													
			ODP	4L312			4L313			4L314													
		50 Hz	TEFC	4L312			4L313			4L314													
			ODP	4L312			4L313			4L314													

	56C	180TC	210TC	250TC	280TC	320TSC	360TSC
1SV	4L188	4L189					
2SV	4L188	4L189					
3SV	4L190	4L191	4L192	4L193			
4SV	4L190	4L191	4L192	4L193			
5SV			4L312	4L313	4L314		
6SV			4L312	4L313	4L314		
33SV							
46SV		4L553	4L554	4L555	4L556		
66SV		4L553	4L554	4L555	4L556		
92SV		4L553	4L554	4L555	4L556		

COUPLING PIN SUPPLIED WITH COUPLING COMPLETE AND SHAFT ASSEMBLY

Size	Pin Repair Part Number
1SV	4L170
2SV	
3SV	4L171
4SV	
33SV	4L83
46SV	
66SV	
92SV	

COUPLING GUARD (COMPLETE WITH HARDWARE)

Pump	Motor Frame				
	56C	180TCH	180TC	210TC - 250TC	280TC
1SV	4L450				
2SV	4L450				
3SV	4L451		4L450	4L452	
4SV		4L451	4L450	4L452	
33-92SV	4L515				

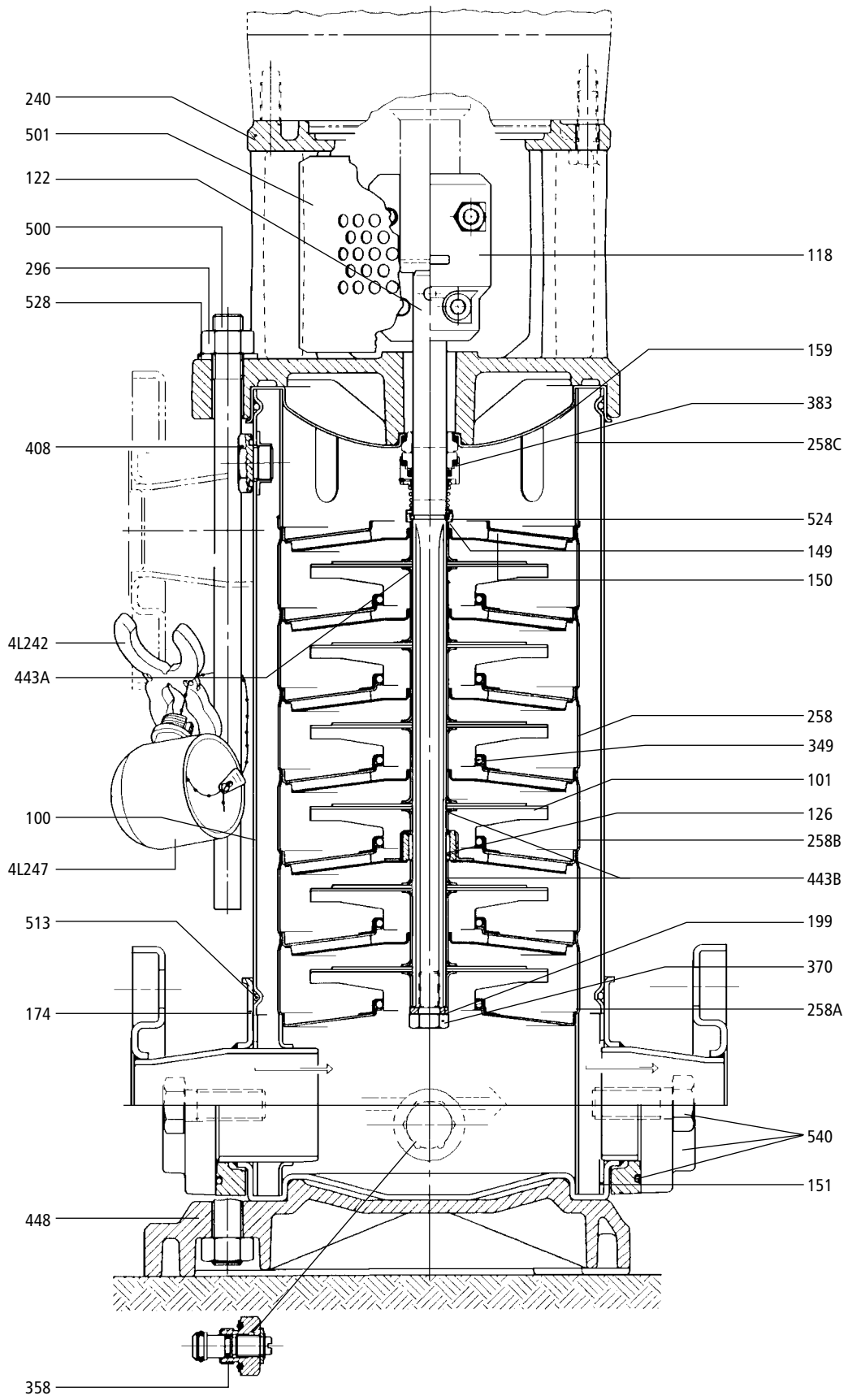

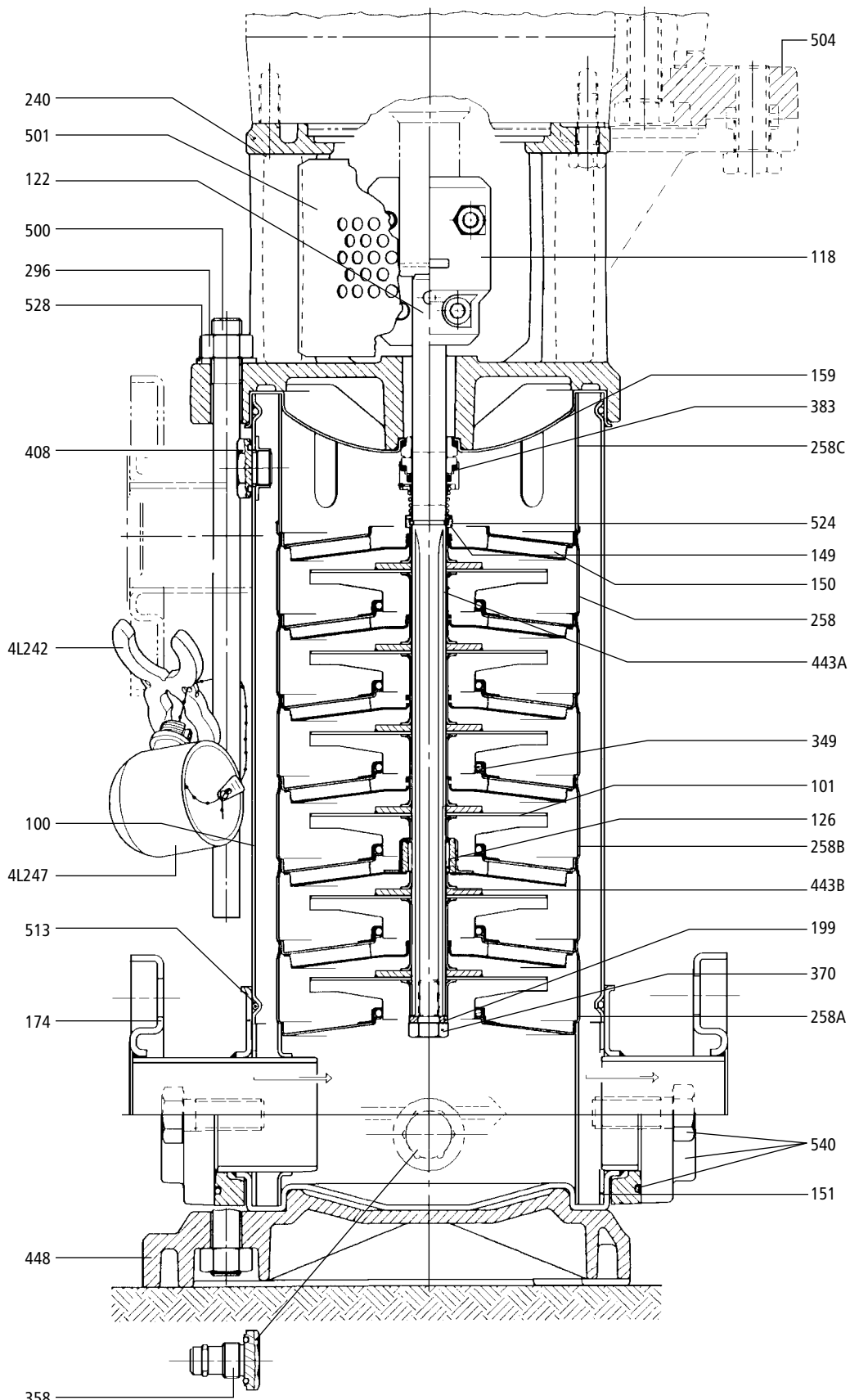

157 Stage spacer is not shown.
Used on 6, 9 and 12 stage units.

3SV AND 4SV

Item No.	Part Name	Pump	Standard Staging - 50 Hz and 60 Hz (*50 Hz only)																Reverse Stack (60 Hz only)		
			Number of Stages																Number of Stages		
			3SV	2	3	4	5	6	7	8	9	10	11	12	13	14*	15*	16*	12	14	16
240	Motor adapter		See motor adapter chart page 17																		
501	Coupling guard		See coupling guard chart page 7																		
122	Shaft assembly includes items 149, 199, 370, 524 and coupling pin	Type A ²	4L254	4L255	4L256	4L257	4L258	4L258	4L259	4L260	4L260	4L261									
		Type B	4L254	4L255	4L256	4L257	4L258	4L258	4L259	4L260	4L260	4L261	4L262	4L262	4L439	4L442	4L442	4L262	4L439	4L440	
		Type C			4L256	4L257	4L258	4L258	4L259	4L260	4L260	4L261	4L262	4L262							
		Type D	4L263	4L264	4L265	4L266	4L267	4L267	4L268	4L269	4L269	4L270	4L271	4L271	4L441	4L442	4L442	4L271	4L441	4L442	
126	Shaft sleeve		4L181																		
100	Casing with fill plug	Type A ²	1L391	1L392	1L393	1L394	1L395	1L395	1L396	1L397	1L397	1L398									
		Type B	1L391	1L392	1L393	1L394	1L395	1L395	1L396	1L397	1L398	1L399	1L399	1L515	1L518	1L518	1L399	1L515	1L518		
		Type C			1L409	1L410	1L411	1L411	1L412	1L413	1L413	1L414	1L415	1L415							
		Type D	1L400	1L401	1L402	1L403	1L404	1L404	1L405	1L406	1L406	1L407	1L408	1L408	1L517	1L518	1L518	1L408	1L517	1L518	
151	Casing spacer	Type A ²	4L173																		
		Type B	4L173																		
		Type C	4L173																		
		Type D	4L251																		
513	O-ring casing		5L94 Viton 5L89 EPR																		
174	Pump body includes item 151	Type A ²	1L339																		
		Type B	1L341																		
		Type C ¹	1L343																		
		Type D	1L389																		
		Victaulic	1L501																		
448	Base plate	Type A ²	1L381																		
		Type B	1L382																		
		Type C	1L382																		
		Type D	1L382																		
		Victaulic	1L382																		
159	Seal housing	Type A ²	1L378																		
		Type B	1L378																		
		Type C	1L378																		
		Type D	1L417																		
383	Mechanical seal with washer		See mechanical seal option table on page 3																		
524	Split ring		4L246																		
149	Split ring cover		4L244																		
258C	Final spacer	Type A ²	4L175																		
		Type B	4L175																		
		Type C	4L175																		
		Type D	4L249																		
150	Final flange diffuser	Type A ²	3L27				3L27				3L27				3L27						
		Type B	3L27				3L27				3L27				3L27						
		Type C	3L27				3L27				3L27				3L27						
		Type D	3L29				3L29				3L29				3L29						
	Final flange without diffuser	Type A ²			4L200				4L200				4L200				4L200				
		Type B			4L200				4L200				4L200				4L200				
		Type C			4L200				4L200				4L200				4L200				
		Type D			4L355				4L355				4L355				4L355				
—	Spacer sleeve, blank stage	Type A ²			4L252				4L252				4L252				4L252				
		Type B			4L252				4L252				4L252				4L252				
		Type C			4L252				4L252				4L252				4L252				
		Type D			4L252				4L252				4L252				4L252				
—	Initial spacer	Type A ²																			
		Type B																			
		Type C																			
		Type D																			
258A	1st stage bowl with o-ring (Viton)	Type A ²	7L355																		
		Type B	3SV = 7L355 4SV = 7L356																		
		Type C	3SV = 7L355 4SV = 7L356																		
		Type D	3SV = 7L364 4SV = 7L365																		
258B	Bowl with bearing and o-ring (Viton)	Type A ²	7L352																		
		Type B	3SV = 7L352 4SV = 7L353																		
		Type C	3SV = 7L352 4SV = 7L353																		
		Type D	3SV = 7L361 4SV = 7L362																		
258	Bowl with o-ring (Viton)	Type A ²	7L349																		
		Type B	3SV = 7L349 4SV = 7L350																		
		Type C	3SV = 7L349 4SV = 7L350																		
		Type D	3SV = 7L358 4SV = 7L359																		
349	O-ring (impeller)		3SV = 5L91 (Viton) 3SV = 5L84 (EPR) 4SV = 5L92 (Viton) 4SV = 5L85																		
101	Impeller		3SV = 2L180 4SV = 2L190																		
443A	Impeller spacer		4L178																		
443B	Impeller spacer (intermediate)		4L179																		
199	Impeller washer (spacer)		13L106																		
370	Impeller screw		13L96																		
500	Tie rod with nuts and washers		4L274	4L275	4L276	4L277	4L278	4L278	4L279	4L280	4L280	4L281	4L282	4L282	4L326	4L327	4L327	4L282	4L326	4L327	
296	Nut, tie rod		13L99																		
528	Washer, tie rod		13L101																		
540	Oval flange assembly (3SVA only)		4L187																		
118	Coupling assembly		See coupling assembly chart on page 5																		
408	Fill plug with o-ring		6L19 Viton 6L25 EPR																		
358	Drain plug with o-ring		6L18 Viton 6L24 EPR																		
—	Shim, coupling		4L242																		
—	Fill funnel		4L247																		

NOTE: Stages 18-24 are available in 50 Hz and reverse stack orientation for 60 Hz applications.
¹Suction body only. ²For use with 3SV only.

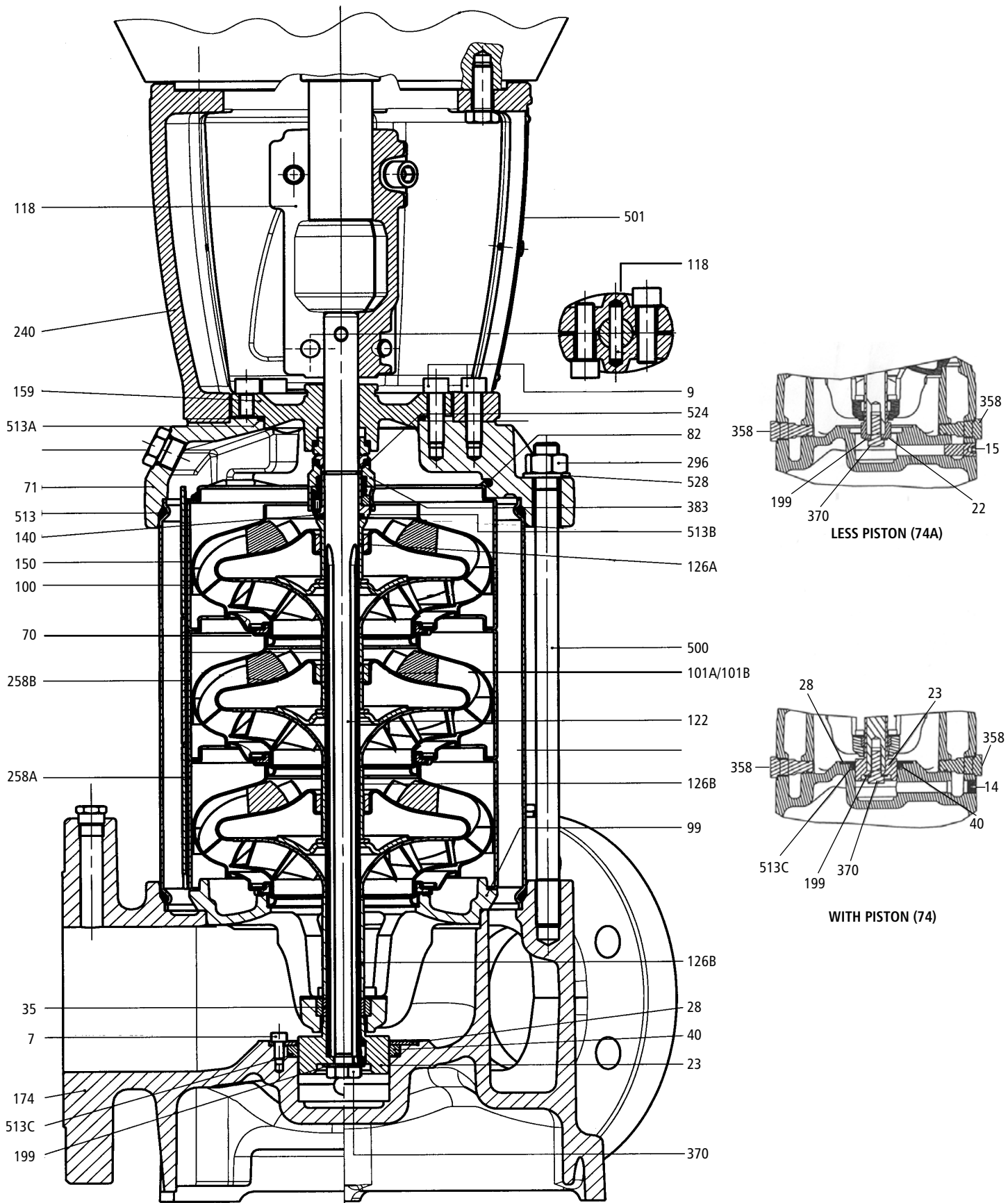

33SV AND 46SV

Item No.	Part Name	Material	33SV										46SV																																																																																																																																																																																																																																																																																																																																																																																																																																																																																										
			Number of Stages										Number of Stages																																																																																																																																																																																																																																																																																																																																																																																																																																																																																										
			1	2	3	4	5	6	7	8	9	10	1	2	3	4	5	6	7	8	9	10																																																																																																																																																																																																																																																																																																																																																																																																																																																																																	
174	Pump body	Class 125	Cast iron	1L640										1L640																																																																																																																																																																																																																																																																																																																																																																																																																																																																																									
		Class 150	SS	1L634										1L636																																																																																																																																																																																																																																																																																																																																																																																																																																																																																									
		Class 250	Cast iron	1L641										1L643																																																																																																																																																																																																																																																																																																																																																																																																																																																																																									
		Class 300	SS	1L635										1L637																																																																																																																																																																																																																																																																																																																																																																																																																																																																																									
71	Pump head	Cast iron	1L632										1L630																																																																																																																																																																																																																																																																																																																																																																																																																																																																																										
		SS	1L630										1L630																																																																																																																																																																																																																																																																																																																																																																																																																																																																																										
	O-ring, kit – EPDM		5K374										5K375																																																																																																																																																																																																																																																																																																																																																																																																																																																																																										
513A	O-ring, seal hsg.	EPDM	5K367										5K367																																																																																																																																																																																																																																																																																																																																																																																																																																																																																										
513B	O-ring, mech. seal sleeve		5K365										5K365																																																																																																																																																																																																																																																																																																																																																																																																																																																																																										
513	O-ring, casing		5L46 (qty. 2)										5L46 (qty. 2)																																																																																																																																																																																																																																																																																																																																																																																																																																																																																										
513C	O-ring, piston		5K248										5K361																																																																																																																																																																																																																																																																																																																																																																																																																																																																																										
	O-ring, kit – Viton		5K376										5K377																																																																																																																																																																																																																																																																																																																																																																																																																																																																																										
513A	O-ring, seal hsg.	Viton	5K368										5K368																																																																																																																																																																																																																																																																																																																																																																																																																																																																																										
513B	O-ring, mech. seal sleeve		5K366										5K366																																																																																																																																																																																																																																																																																																																																																																																																																																																																																										
513	O-ring, casing		5L42 (qty. 2)										5L42 (qty. 2)																																																																																																																																																																																																																																																																																																																																																																																																																																																																																										
513C	O-ring, piston		5L90										5K362																																																																																																																																																																																																																																																																																																																																																																																																																																																																																										
159	Seal housing	Cast iron	1L629										1L629																																																																																																																																																																																																																																																																																																																																																																																																																																																																																										
		SS	1L628										1L628																																																																																																																																																																																																																																																																																																																																																																																																																																																																																										
383	Mechanical seal		See optional seal table on page 4																																																																																																																																																																																																																																																																																																																																																																																																																																																																																																				
	Screw, seal housing	Zinc plated	13L127 (qty. 4)										13L127 (qty. 4)																																																																																																																																																																																																																																																																																																																																																																																																																																																																																										
	Plug, vent with o-ring	EPDM	6L49										6L49																																																																																																																																																																																																																																																																																																																																																																																																																																																																																										
		Viton	6L53										6L53																																																																																																																																																																																																																																																																																																																																																																																																																																																																																										
	Plug, fill with o-ring	EPDM	6L48										6L48																																																																																																																																																																																																																																																																																																																																																																																																																																																																																										
		Viton	6L52										6L52																																																																																																																																																																																																																																																																																																																																																																																																																																																																																										
358	Plug, drain with o-ring	EPDM	6L50 (qty. 2)										6L50 (qty. 2)																																																																																																																																																																																																																																																																																																																																																																																																																																																																																										
		Viton	6L54 (qty. 2)										6L54 (qty. 2)																																																																																																																																																																																																																																																																																																																																																																																																																																																																																										
370	Bolt, impeller	316SS	13L109										13L109																																																																																																																																																																																																																																																																																																																																																																																																																																																																																										
199	Washer, impeller	316SS	13L129										13L129																																																																																																																																																																																																																																																																																																																																																																																																																																																																																										
126A	Spacer, final	316SS	4L509										4L509																																																																																																																																																																																																																																																																																																																																																																																																																																																																																										
126B	Spacer, impeller	316SS	4L511										4L511																																																																																																																																																																																																																																																																																																																																																																																																																																																																																										
140	Sleeve, mechanical seal shaft	316SS	4L531										4L531																																																																																																																																																																																																																																																																																																																																																																																																																																																																																										
524	Stop ring, impeller	316SS	4L550										4L550																																																																																																																																																																																																																																																																																																																																																																																																																																																																																										
82	Spring, diffuser	316SS	4L551										4L551																																																																																																																																																																																																																																																																																																																																																																																																																																																																																										
150	Diffuser, final stage	316LSS	3L42										3L42																																																																																																																																																																																																																																																																																																																																																																																																																																																																																										
258A	Diffuser, carbon bearing	316LSS	3L44										3L45																																																																																																																																																																																																																																																																																																																																																																																																																																																																																										
	Diffuser, tungsten carbide	316LSS	3L48										3L49																																																																																																																																																																																																																																																																																																																																																																																																																																																																																										
258B	Spacer, shaft bushing	316SS	4L510 (qty. 2)										4L510 (qty. 2)																																																																																																																																																																																																																																																																																																																																																																																																																																																																																										
	Bearing	Tung. carb.	4L514										4L514																																																																																																																																																																																																																																																																																																																																																																																																																																																																																										
70	Wear ring, impeller/diffuser (qty. 5)	316LSS / PPS	15L47										15L48																																																																																																																																																																																																																																																																																																																																																																																																																																																																																										
		Cast iron	15L39										15L40																																																																																																																																																																																																																																																																																																																																																																																																																																																																																										
99	Lower bracket assembly	SS	15L35										15L36																																																																																																																																																																																																																																																																																																																																																																																																																																																																																										
	Thrust piston assembly		15K51										15K52																																																																																																																																																																																																																																																																																																																																																																																																																																																																																										
	23 – piston	Duplex SS	4L494										4L495																																																																																																																																																																																																																																																																																																																																																																																																																																																																																										
	40 – Piston seal	Impregnated carbon	4L547										4L548																																																																																																																																																																																																																																																																																																																																																																																																																																																																																										
	28 – Retaining plate	316SS	4L506										4L507																																																																																																																																																																																																																																																																																																																																																																																																																																																																																										
	513C – O-ring viton, piston	Viton	5L90										5K362																																																																																																																																																																																																																																																																																																																																																																																																																																																																																										
	513C – O-ring EPDM, piston	EPDM	5K248										5K361																																																																																																																																																																																																																																																																																																																																																																																																																																																																																										
	14 – Plug	316SS	6L47										6L47																																																																																																																																																																																																																																																																																																																																																																																																																																																																																										
	7 – Hex cap screws	316SS	13L114 (qty. 3)										13L114 (qty. 3)																																																																																																																																																																																																																																																																																																																																																																																																																																																																																										
	35 – Bearing	Tung. carb.	4L514										4L514																																																																																																																																																																																																																																																																																																																																																																																																																																																																																										
74A	Non-piston assembly		15K54										15K54																																																																																																																																																																																																																																																																																																																																																																																																																																																																																										
	22 – Bushing, impeller	316SS	4L513										4L513																																																																																																																																																																																																																																																																																																																																																																																																																																																																																										
	15 – Plug	316SS	6L51										6L51																																																																																																																																																																																																																																																																																																																																																																																																																																																																																										
	35 – Bearing	Tung. carb.	4L514										4L514																																																																																																																																																																																																																																																																																																																																																																																																																																																																																										
101A	Impeller, full diameter	316LSS	2L899										2L900																																																																																																																																																																																																																																																																																																																																																																																																																																																																																										
101B	Impeller, reduced diameter	316LSS	2L903										2L904																																																																																																																																																																																																																																																																																																																																																																																																																																																																																										
122	Shaft assembly	Duplex SS	4L516	4L517	4L518	4L519	4L520	4L521	4L522	4L523	4L524	4L525	4L526	4L527	4L528	4L529	4L530	4L531	4L532	4L533	4L534	4L535	4L536	4L537	4L538	4L539	4L540	4L541	4L542	4L543	4L544	4L545	4L546	4L547	4L548	4L549	4L550	4L551	4L552	4L553	4L554	4L555	4L556	4L557	4L558	4L559	4L560	4L561	4L562	4L563	4L564	4L565	4L566	4L567	4L568	4L569	4L570	4L571	4L572	4L573	4L574	4L575	4L576	4L577	4L578	4L579	4L580	4L581	4L582	4L583	4L584	4L585	4L586	4L587	4L588	4L589	4L590	4L591	4L592	4L593	4L594	4L595	4L596	4L597	4L598	4L599	4L600	4L601	4L602	4L603	4L604	4L605	4L606	4L607	4L608	4L609	4L610	4L611	4L612	4L613	4L614	4L615	4L616	4L617	4L618	4L619	4L620	4L621	4L622	4L623	4L624	4L625	4L626	4L627	4L628	4L629	4L630	4L631	4L632	4L633	4L634	4L635	4L636	4L637	4L638	4L639	4L640	4L641	4L642	4L643	4L644	4L645	4L646	4L647	4L648	4L649	4L650	4L651	4L652	4L653	4L654	4L655	4L656	4L657	4L658	4L659	4L660	4L661	4L662	4L663	4L664	4L665	4L666	4L667	4L668	4L669	4L670	4L671	4L672	4L673	4L674	4L675	4L676	4L677	4L678	4L679	4L680	4L681	4L682	4L683	4L684	4L685	4L686	4L687	4L688	4L689	4L690	4L691	4L692	4L693	4L694	4L695	4L696	4L697	4L698	4L699	4L700	4L701	4L702	4L703	4L704	4L705	4L706	4L707	4L708	4L709	4L710	4L711	4L712	4L713	4L714	4L715	4L716	4L717	4L718	4L719	4L720	4L721	4L722	4L723	4L724	4L725	4L726	4L727	4L728	4L729	4L730	4L731	4L732	4L733	4L734	4L735	4L736	4L737	4L738	4L739	4L740	4L741	4L742	4L743	4L744	4L745	4L746	4L747	4L748	4L749	4L750	4L751	4L752	4L753	4L754	4L755	4L756	4L757	4L758	4L759	4L760	4L761	4L762	4L763	4L764	4L765	4L766	4L767	4L768	4L769	4L770	4L771	4L772	4L773	4L774	4L775	4L776	4L777	4L778	4L779	4L780	4L781	4L782	4L783	4L784	4L785	4L786	4L787	4L788	4L789	4L790	4L791	4L792	4L793	4L794	4L795	4L796	4L797	4L798	4L799	4L800	4L801	4L802	4L803	4L804	4L805	4L806	4L807	4L808	4L809	4L810	4L811	4L812	4L813	4L814	4L815	4L816	4L817	4L818	4L819	4L820	4L821	4L822	4L823	4L824	4L825	4L826	4L827	4L828	4L829	4L830	4L831	4L832	4L833	4L834	4L835	4L836	4L837	4L838	4L839	4L840	4L841	4L842	4L843	4L844	4L845	4L846	4L847	4L848	4L849	4L850	4L851	4L852	4L853	4L854	4L855	4L856	4L857	4L858	4L859	4L860	4L861	4L862	4L863	4L864	4L865	4L866	4L867	4L868	4L869	4L870	4L871	4L872	4L873	4L874	4L875	4L876	4L877	4L878	4L879	4L880	4L881	4L882	4L883	4L884	4L885	4L886	4L887	4L888	4L889	4L890	4L891	4L892	4L893	4L894	4L895	4L896	4L897	4L898	4L899	4L900	4L901	4L902	4L903	4L904	4L905	4L906	4L907	4L908	4L909	4L910	4L911	4L912	4L913	4L914	4L915	4L916	4L917	4L918	4L919	4L920	4L921	4L922	4L923	4L924	4L925	4L926	4L927	4L928	4L929	4L930	4L931	4L932	4L933	4L934	4L935	4L936	4L937	4L938	4L939	4L940	4L941	4L942	4L943	4L944	4L945	4L946	4L947	4L948	4L949	4L950	4L951	4L952	4L953	4L954	4L955	4L956	4L957	4L958	4L959	4L960	4L961	4L962	4L963	4L964	4L965	4L966	4L967	4L968	4L969	4L970	4L971	4L972	4L973	4L974	4L975	4L976	4L977	4L978	4L979	4L980	4L981	4L982	4L983	4L984	4L985	4L986	4L987	4L988	4L989	4L990	4L991	4L992	4L993	4L994	4L995	4L996	4L997	4L998	4L999	4L1000
100	Casing (25 bar max)	316LSS	4L532	4L533	4L534	4L535	4L536	4L537	4L538	4L539	4L540	4L541	4L542	4L543	4L544	4L545	4L546	4L547	4L548	4L549	4L550	4L551	4L552	4L553	4L554	4L555	4L556	4L557	4L558	4L559	4L560	4L561	4L562	4L563	4L564	4L565	4L566	4L567	4L568	4L569	4L570	4L571	4L572	4L573	4L574	4L575	4L576	4L577	4L578	4L579	4L580	4L581	4L582	4L583	4L584	4L585	4L586	4L587	4L588	4L589	4L590	4L591	4L592	4L593	4L594	4L595	4L596	4L597	4L598	4L599	4L600	4L601	4L602	4L603	4L604	4L605	4L606	4L607	4L608	4L609	4L610	4L611	4L612	4L613	4L614	4L615	4L616	4L617	4L618	4L619	4L620	4L621	4L622	4L623	4L624	4L625	4L626	4L627	4L628	4L629	4L630	4L631	4L632	4L633	4L634	4L635	4L636	4L637	4L638	4L639	4L640	4L641	4L642	4L643	4L644	4L645	4L646	4L647	4L648	4L649	4L650	4L651	4L652	4L653	4L654	4L655	4L656	4L657	4L658	4L659	4L660	4L661	4L662	4L663	4L664	4L665	4L666	4L667	4L668	4L669	4L670	4L671	4L672	4L673	4L674	4L675	4L676	4L677	4L678	4L679	4L680	4L681	4L682	4L683	4L684	4L685	4L686	4L687	4L688	4L689	4L690	4L691	4L692	4L693	4L694	4L695	4L696	4L697	4L698	4L699	4L700	4L701	4L702	4L703	4L704	4L705	4L706	4L707	4L708	4L709	4L710	4L711	4L712	4L713	4L714	4L715	4L716	4L717	4L718	4L719	4L720	4L721	4L722	4L723	4L724	4L725	4L726	4L727	4L728	4L729	4L730	4L731	4L732	4L733	4L734	4L735	4L736	4L737	4L738	4L739	4L740	4L741	4L742	4L743	4L744	4L745	4L746	4L747	4L748	4L749	4L750	4L751	4L752	4L753	4L754	4L755	4L756	4L757	4L758	4L759	4L760	4L761	4L762	4L763	4L764	4L765	4L766	4L767	4L768	4L769	4L770	4L771	4L772	4L773	4L774	4L775	4L776	4L777	4L778	4L779	4L780	4L781	4L782	4L783	4L784	4L785	4L786	4L787	4L788	4L789	4L790	4L791	4L792	4L793	4L794	4L795	4L796	4L797	4L798	4L799	4L800	4L801	4L802	4L803	4L804	4L805	4L806	4L807	4L808	4L809	4L810	4L811	4L812	4L813	4L814	4L815	4L816	4L817	4L818	4L819	4L820	4L821	4L822	4L823	4L824	4L825	4L826	4L827	4L828	4L829	4L830	4L831	4L832	4L833	4L834	4L835	4L836	4L837	4L838	4L839	4L840	4L841	4L842	4L843	4L844	4L845	4L846	4L847	4L848	4L849	4L850	4L851	4L852	4L853	4L854	4L855	4L856	4L857	4L858	4L859	4L860	4L861	4L862	4L863	4L864	4L865	4L866	4L867	4L868	4L869	4L870	4L871	4L872	4L873	4L874	4L875	4L876	4L877	4L878	4L879	4L880	4L881	4L882	4L883	4L884	4L885	4L886	4L887	4L888	4L889	4L890	4L891	4L892	4L893	4L894	4L895																																																																																																																									

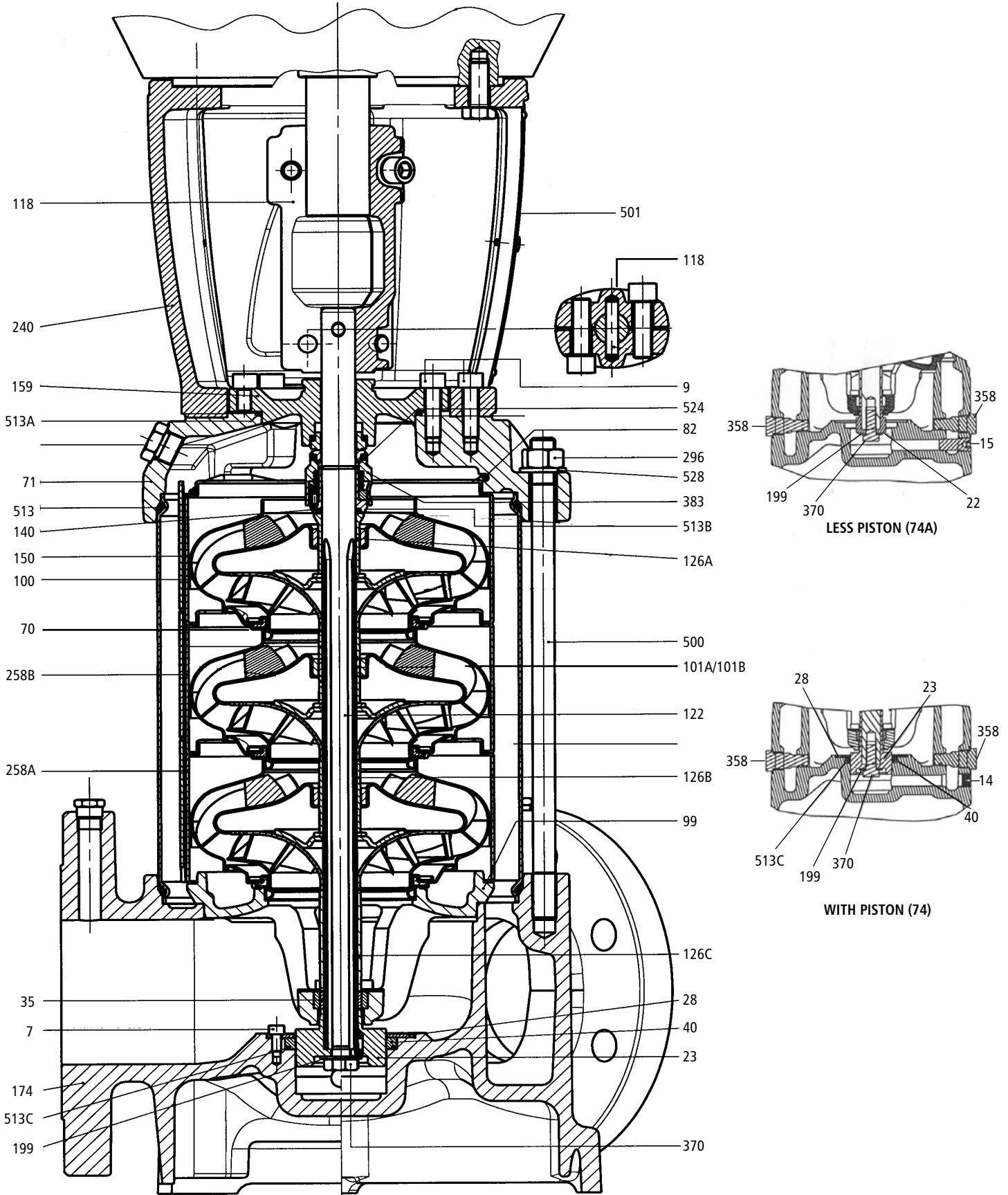

66SV AND 92SV

Item No.	Part Name	Material	66SV						92SV							
			Number of Stages						Number of Stages							
			1	2	3	4	5	6	1	2	3	4	5	6		
174	Pump body	Class 125	Cast iron							11644						
		Class 150	SS							11638						
		Class 250	Cast iron							11645						
		Class 300	SS							11639						
71	Pump head	Cast iron							11633							
		SS							11631							
513A	O-ring, kit – EPDM	EPDM							5K378							
	– O-ring, seal housing								5K367							
513B	– O-ring, mech. seal sleeve								5K365							
513	– O-ring, casing								5L47 (qty. 2)							
513C	– O-ring, piston								5K363							
	O-ring, kit – Viton	Viton							5K379							
513A	– O-ring, seal housing								5K368							
513B	– O-ring, mech. seal sleeve								5K366							
513	– O-ring, casing								5L43 (qty. 2)							
513C	– O-ring, piston								5K364							
159	Seal housing	Cast iron							11629							
		SS							11628							
383	Mechanical seal options		See optional seal table on page 4													
–	Screw, seal housing	Zinc plated							13L127 (qty. 4)							
	Plug, vent w/o-ring	EPDM							6L49							
		Viton							6L53							
	Plug, fill w/o-ring	EPDM							6L48							
		Viton							6L52							
358	Plug, drain w/o-ring	EPDM							6L50 (qty. 2)							
		Viton							6L54 (qty. 2)							
370	Bolt, impeller	316SS							13L109							
199	Washer, impeller	316SS							13L129							
126A	Spacer, final	316SS							4L509							
126B	Spacer, impeller	316SS							4L511							
126C	Spacer, impeller	316SS							4L512							
140	Sleeve, mech. seal shaft	316SS							4L531							
524	Stop ring, impeller	316SS							4L550							
82	Spring, diffuser	316SS							4L552							
150	Diffuser, final stage	316LSS							3L43							
258A	Diffuser, carbon bearing	316LSS			3L46							3L47				
	Diffuser, tungsten carbide	316LSS			3L50							3L51				
258B	Spacer, shaft bushing	316SS							4L510 (qty. 2)							
	Bearing	Tung. carb.							4L514							
70	Wear ring, Impeller/Diffuser (qty. 5)	316LSS / PPS			15L49							15L50				
99	Lower bracket assembly	Cast iron			15L41							15L42				
		SS			15L37							15L38				
74	Thrust piston assembly								15K53							
	23 – Piston	Duplex SS							4L496							
	40 – Piston seal	Impregnated carbon							4L549							
	28 – Retaining plate	316SS							4L508							
	513C – O-ring viton, piston	Viton							5K364							
	513C – O-ring EPDM, piston	EPDM							5K363							
	14 – Plug	316SS							6L47							
	7 – Hex cap screws	316SS							13L114 (qty. 3)							
74A	35 – Bearing	Tung. carb.							4L514							
	Non-piston assembly								15K54							
	22 – Bushing, impeller stack	316SS							4L513							
	15 – Plug	316SS							6L51							
	35 – Bearing	Tung. Carb.							4L514							
101A	Impeller, full diameter	316LSS			2L901						2L902					
101B	Impeller, reduced diameter	316LSS			2L905						2L906					
122	Shaft assembly	Duplex SS	4L525	4L526	4L527	4L528	4L529	4L530	4L525	4L526	4L527	4L528	4L529	4L530		
100	Casing (25 bar max)	316LSS	4L541	4L542	4L543	4L544	4L545	4L546	4L541	4L542	4L543	4L544	4L545	4L546		
	Casing (40 bar max)	316LSS	4L585	4L586	4L587	4L580	4L481	4L582	4L585	4L586	4L587	4L580	4L581	4L582		
500	Tie-rods – qty. 4 with hardware	Zinc plated	4L570	4L571	4L572	4L573	4L562	4L574	4L570	4L571	4L572	4L573	4L562	4L574		
528	Washer, tie-rod	Zinc plated							13K307 (qty. 4)							
296	Hex nut, tie-rod	Zinc plated							13K366 (qty. 4)							
118	Coupling assembly with pin, shim fork and hardware	180TC	Cast iron							4L553						
		210TC								4L554						
		250TC									4L555					
		280TC – 360TSC									4L556					
501	Guard, coupling assembly	304SS							4L515							
240	Motor adapter	180TC – 360TSC	Cast iron						11649							
–	Adapter plate (not shown)	280TC	Cast iron							11646						
		320TSC								11647						
		360TSC									11648					
–	Hex cap screw, motor	180TC – 250TC	Zinc plated							13K103 (qty. 4)						
		280TC								13K44 (qty. 4) or 13K245 (qty. 4)						
		320TSC									13K44 (qty. 4) or 13K247 (qty. 4)					
		360TSC									13K44 (qty. 4) or 13K247 (qty. 4)					
9	Hex cap screw, motor adapter	Zinc plated							13L127 (qty. 4)							
–	Shim fork	Plastic							4L242							

OPTIONAL VICTAULIC MATING COMPONENTS

Size	Victaulic Coupling	Victaulic Threaded Coupling
1SV	4L194	4L196
2SV		
3SV	4L195	4L197
4SV		

REPLACEMENT O-RING FOR OVAL FLANGE ASSEMBLY

Size	O-Ring Repair Part Number
1SV	5L107
2SV	
3SV	5L108

OPTIONAL HORIZONTAL MOUNTING FOOT

Size	Suction Flange Location	Pump Mounting Bracket	Shim Required determined by Motor Frame Size						
			56C	180TC	210TC	250TC	280TC	320TSC	360TSC
1SV	Horizontal	9L92	13K249 (qty. 4)	No Shim Required					
	Vertical	9L93							
2SV	Horizontal	9L92							
	Vertical	9L93							
3SV	Horizontal	9L90	13K249 (qty. 4) 13K346 (qty. 4)	13K346 (qty. 4)	13K249 (qty. 4)	No Shim Required			
	Vertical	9L91							
4SV	Horizontal	9L90							
	Vertical	9L91							
33SV	Horizontal	9K442		9K440 (qty. 2)	9K441 (qty. 2)	13K249 (qty. 8)	13K249 (qty. 4)	No Shim Required	
46SV		9K443							
66SV									
92SV									
5SV (OBSOLETE)									Horizontal
6SV (OBSOLETE)									

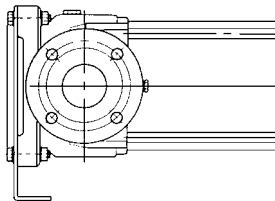

MOTOR ADAPTER AND ADAPTER RINGS TABLE

PUMP	ODP-TEFC	ODP-TEFC	ODP-TEFC	ODP	ODP	TEFC	ODP	TEFC	ODP	TEFC	TEFC	ODP	TEFC	ODP	TEFC	ODP	
	56C	184TCH	184TC	213TC	215TC		254TC		256TC		284TC						286TC
	HP 0.5 to 3	HP 5 to 7.5	HP 5 to 7.5	HP 10	HP 15	HP 10	HP 20	HP 15	HP 25	HP 20	HP 25	HP 30	HP 30	HP 40	HP 40	HP 50	
1SV	Motor Adapter 1L383		Motor Adapter 1K327														
2SV																	
3SV	Motor Adapter 1L384		Motor Adapter 1K328	Adapter Flange 1L386													
4SV				Motor Adapter 1L385													
5SV (Obsolete)				Adapter Flange 1L386						Adapter Flange 1L439							
6SV (Obsolete)				Motor Adapter Iron = 1L437 Stainless = 1L438			Horizontal Mounted Iron = 1L525 Stainless = 1L526			Motor Adapter Iron = 1L437 Stainless = 1L438			Horizontal Mounted Iron = 1L525 Stainless = 1L526				

Pump	180TC	210TC	250TC	280TC	320TSC	360TSC
	HP 5 to 7.5	HP 7.5 to 15	HP 15 to 25	HP 25 to 40	HP 50 to 60	HP 60 to 75
33SV	Motor Adapter 1L649			Motor Adapter 1L649 Adapter fig. 1L646	Motor Adapter 1L649 Adapter fig. 1L647	Motor Adapter 1L649 Adapter fig. 1L648
46SV						
66SV						
92SV						

5SV AND 6SV WITHOUT CROSSOVER

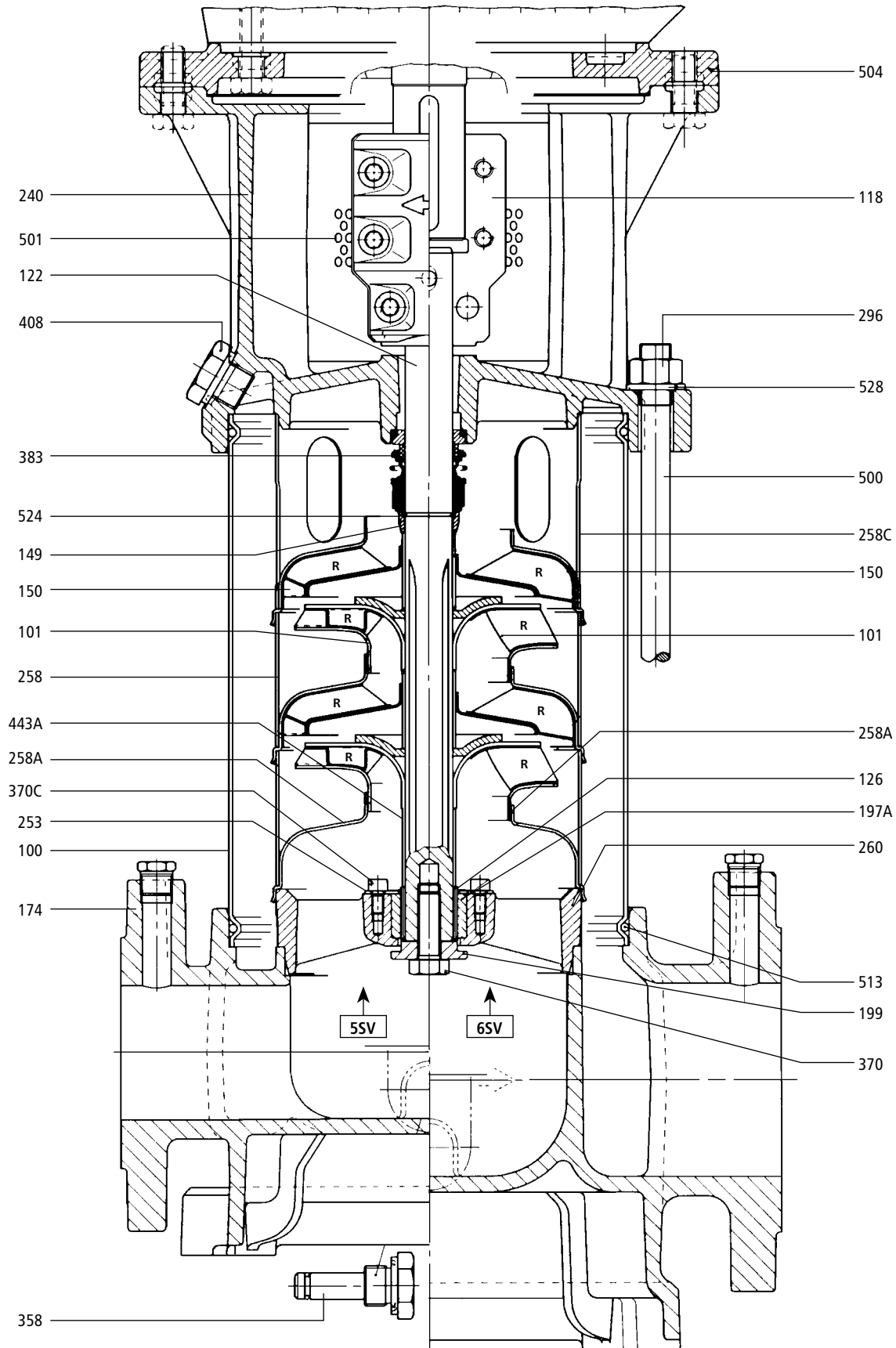

159 Seal Housing Type D is not shown.

5SV AND 6SV WITHOUT CROSSOVER

Item No.	Part Name	Number of Stages			
		2	3	4	
240	Motor adapter	See motor adapter chart page 17			
504	Adapting flange (motor mounting)				
501	Coupling guard - old snap in	4L289			
	Coupling guard - new with screws	4L453			
122	Shaft assembly includes items 149, 199, 370, 524 and coupling pin	Type B	4L290	4L291	4L292
		Type C	4L297	4L298	4L299
126	Shaft sleeve	4L287			
100	Casing upper	Type B	1L424	1L425	1L426
		Type D	1L430	1L431	1L432
513	O-ring casing	5L42 Viton	5L95 EPR		
174	Pump body	5SV Type B	1L418		1L419
		5SV Type D	1L421		
		6SV Type B	1L420		
		6SV Type D	1L423		
197A	Bushing	7L366			
253	Bearing retainer	4L319			
370C	Bearing fixing screw	13L65			
260	Lower support	Type B	4L318		
		Type D	4L317		
159	Seal housing (Type D only)	1L436			
383	Mechanical seal with washer	See optional seal table on page 1			
524	Split ring	4L311			
149	Split ring cover	4L288			
258	Final spacer	4L285			
258	Stage spacer	4L286			
150	Right hand diffuser	5SV	3L30		
		6SV	3L31		
258A	1st stage bowl	5SV	7L367		
		6SV	7L368		
101	Impeller right hand	5SV	2L240		
		6SV	2L260		
443A	Impeller spacer	4L284			
199	Impeller fixing washer	13L112			
370	Impeller fixing screw	13L109			
500	Tie rod with nuts and washer	4L304	4L305	4L306	
296	Nut tie rod	13L110			
528	Washer tie rod	13L111			
118	Coupling complete	See coupling chart on page 3			
408	Fill plug with o-ring	Type B	6L22 Viton	6L28 EPR	
		Type D	6L19 Viton	6L25 EPR	
358	Drain plug with o-ring	Type B	6L21 Viton	6L27 EPR	
		Type D	6L21 Viton	6L27 EPR	
—	Motor assembly shim	4L242			
—	Filling funnel	4L247			

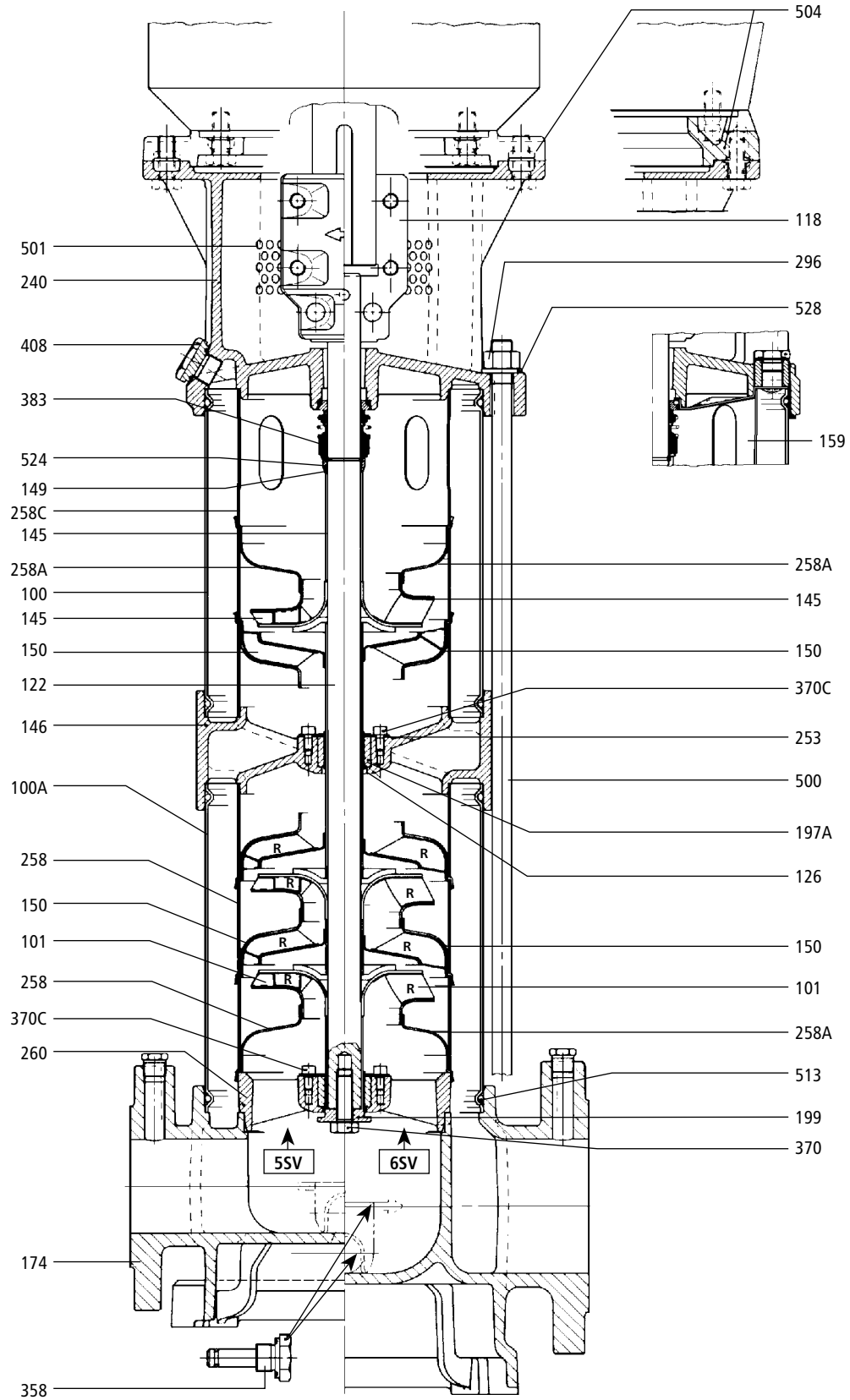

5SV AND 6SV WITH CROSSOVER

Item No.	Part Name	Number of Stages									
		5	6	7	8	9	10	11	12		
240	Motor adapter	See motor adapter chart page 17									
504	Adapting flange (motor mounting)										
501	Coupling guard - old snap in	4L289									
	Coupling guard - new with screws	4L453									
122	Shaft assembly includes items 149, 199, 370, 524 and coupling pin	Type B	4L293	4L294	4L295	4L296	4L345	4L346	4L347	4L348	
		Type D	4L300	4L301	4L302	4L303	4L349	4L350	4L351	4L352	
126	Shaft sleeve	4L287									
100	Casing upper	Type B	1L427	1L427	1L428	1L428	1L429	1L429	1L521	1L521	
		Type D	1L433	1L433	1L434	1L434	1L435	1L435	1L523	1L523	
	Casing lower	Type B	1L427	1L428	1L428	1L429	1L429	1L521	1L521	1L522	
		Type D	1L433	1L434	1L434	1L435	1L435	1L523	1L523	1L524	
146	Intermediate support	Type B	4L315								
		Type D	4L316								
513	O-ring casing	5L42 Viton		5L95 EPR							
174	Pump body	5SV Type B	1L419								
		5SV Type D	1L422								
		6SV Type B	1L420	1L419							
		6SV Type D	1L423	1L422							
197A	Bushing	7L366									
253	Bearing retainer	4L319									
370C	Bearing fixing screw	13L65									
260	Lower support	Type B	4L318								
		Type D	4L317								
159	Seal housing (Type D only)	1L436									
383	Mechanical seal with washer	See optional seal table on page 1									
524	Split ring	4L311									
149	Split ring cover	4L288									
258	Final spacer	4L285									
258	Stage spacer	4L286									
150	Right hand diffuser	5SV	3L30								
		6SV	3L31								
	Left hand diffuser	5SV	3L32								
		6SV	3L33								
258A	1st stage bowl	5SV	7L367								
		6SV	7L368								
101	Impeller right hand	5SV	2L240								
		6SV	2L260								
145	Impeller left hand	5SV	2L250								
		6SV	2L270								
443A	Impeller spacer	4L284									
199	Impeller fixing washer	13L112									
370	Impeller fixing screw	13L109									
500	Tie rod with nuts and washer	4L307	4L308	4L309	4L310	4L328	4L329	4L330	4L331		
296	Nut tie rod	13L110									
528	Washer tie rod	13L111									
118	coupling complete	See coupling chart on page 3									
408	Fill plug with o-ring	Type B	6L22 Viton	6L28 EPR							
		Type D	6L19 Viton	6L25 EPR							
358	Drain plug with o-ring	Type B	6L21 Viton	6L27 EPR							
		Type D	6L21 Viton	6L27 EPR							
—	Motor assembly shim	4L242									
—	Filling funnel	4L247									

NOTE: Stages 9-12 are available in 5SV 50 Hz only.

5SV AND 6SV WITH CROSSOVER

Number of Stages	Number of Impellers	
	Above Crossover (Left Hand)	Below Crossover (Right Hand)
5	2	3
6	2	4
7	3	4
8	3	5
9	4	5
10	4	6
11	5	6
12	5	7

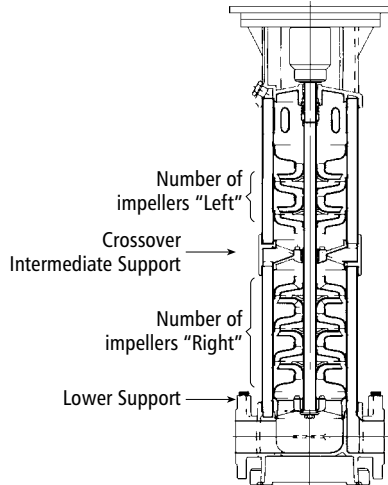

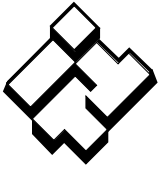

ITT

Commercial Water



Goulds Pumps, G&L and the ITT Engineered Blocks Symbol are registered trademarks and tradenames of ITT Industries Inc.

SPECIFICATIONS ARE SUBJECT TO CHANGE WITHOUT NOTICE.

RSSV January, 2006

© 2006 ITT Water Technology, Inc.

Engineered for life