



# Installation, Operation and Maintenance Instructions

## G&L STAINLESS STEEL Centrifugal Pump Model SST-C and Model SST-F

### I. Important:

- A. Inspect unit for damage. Report damage to carrier immediately.
- B. Electrical supply must be a separate branch circuit with fuses or circuit breakers, wire sizes, etc., per National and Local electrical codes. Install an all-leg disconnect switch near pump. **Caution:** Always disconnect electrical power when handling pump or controls.
- C. Motors must be wired for proper voltage (check nameplate). Wire size must limit maximum voltage drop to 10% of nameplate voltage at motor terminals, or motor life and pump performance will be lowered.
- D. **Single-Phase:** Thermal protection for single-phase units is sometimes built-in (Check nameplate). If no built-in protection is provided, use a contactor with proper overload. Fusing is permissible if properly fused.
- E. **Three-Phase:** Provide three-leg protection with proper size magnetic starter and thermal overloads.
- F. Maximum Liquid Temperatures:  
212°F (100°C) with standard seal.  
250°F (120°C) with optional high-temperature seal.
- G. Maximum allowable operating pressure: 175 PSI.
- H. Maximum Number of Starts per Hour: 20, evenly distributed.
- I. Regular Inspection and Maintenance will increase service life. Base schedule on operating time.

### II. Installation:

- A. Close-coupled units may be installed inclined or vertical. **Caution:** Do not install with motor below pump. Condensation will build up in motor.
- B. Locate pump as near liquid source as possible (Below level of liquid for automatic operation).
- C. Protect from freezing or floods.
- D. Allow adequate space for servicing and ventilation.
- E. For close-coupled pumps, the foundation must be flat and substantial to eliminate strain when tightening bolts. Use rubber mounts to minimize noise and vibration. Tighten motor hold-down bolts before connecting piping to pump.

- F. For frame-mounted pumps, permanent and solid foundation is required for smooth operation. Bedplate must be grouted to a foundation with solid footing.
- G. Place unit in position on wedges located at four points (Two below approximate center of driver and two below approximate center of pump). Adjust wedges to level unit, bringing coupling halves into reasonable alignment. Level or plumb suction and discharge flanges.
- H. Make sure bedplate is not distorted and final coupling alignment can be made within the limits of movement of motor and by shimming if necessary.
- I. Tighten foundation bolts finger tight and build dam around foundation. Pour grout under bedplate making sure the areas under pump and motor feet are filled solid. Allow grout to harden 48 hours before further tightening foundation bolts.
- J. All piping must be supported independently of the pump, and must "line-up" naturally. **Never draw piping into place by forcing the pump suction and discharge connections!**
- K. Angular alignment of the flanges can best be accomplished using calipers at bolt locations (See illustration).

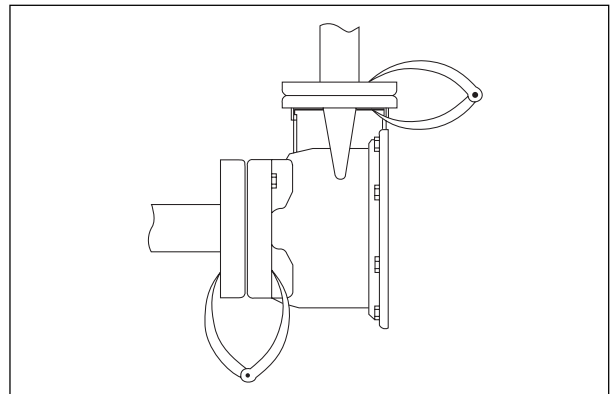

- L. On frame-mounted units, tighten foundation, pump and driver hold-down bolts before connecting piping to pump.
- M. Avoid unnecessary fittings. Select sizes to keep friction losses low.
- N. After completing piping, rotate unit by hand to check for binding. (Note: A screwdriver slot or flats are provided in end of motor shaft.)

### III. Alignment:

- A. No field alignment is necessary on close-coupled pumps.
- B. Even though the pump-motor unit may have a factory alignment, in transit this alignment could be disturbed and must be checked prior to running.
- C. Check the tightness of all hold-down bolts before checking the alignment.
- D. If re-alignment is necessary, always move the motor. Shim as required.
- E. Final alignment is achieved when parallel and angular requirements are achieved with both pump and motor hold-down bolts tight. **Caution:** Always recheck both alignments after making adjustments.
- F. Parallel misalignment exists when the shafts are not concentric. Place dial indicator on one hub and rotate this hub 360° while taking readings on the outside diameter of the other hub. Parallel alignment occurs when Total Indicator Reading is .005" or less.
- G. Angular misalignment exists when the shafts are not parallel. Place dial indicator on one hub and rotate this hub 360° while taking readings on the face of the other hub. Angular alignment is achieved when Total Indicator Reading is .005" or less.

### IV. Suction Piping:

- A. Low static lift and short, direct suction piping is desired. For suction lift over 15 feet, consult pump performance curve for Net Positive Suction Head Required.
- B. Suction pipe size must be at least equal to suction connection of pump.
- C. If larger pipe is used, an eccentric pipe reducer (with straight side up) must be used at the pump.
- D. Installation with **pump below source** of supply:
  - 1. Install isolation valve in piping for inspection and maintenance.
  - 2. **Do not use suction isolation valve to throttle pump!**
- E. Installation with **pump above source** of supply:
  - 1. To avoid air pockets, no part of piping should be higher than pump suction connection. Slope piping upwards from liquid source.
  - 2. All joints must be airtight.
  - 3. Foot valve to be used only if necessary for priming, or to hold prime on intermittent service.
  - 4. Suction strainer open area must be at least triple the pipe area.
- F. Size of inlet from liquid source, and minimum submergence over inlet, must be sufficient to prevent air entering pump.

### V. Discharge Piping:

- A. Arrangement must include a check valve located between a gate valve and the pump. The gate valve is for regulation of capacity, or inspection of pump or check valve.
- B. If reducer is required, place between check valve and pump.

### VI. Rotation:

- A. Pumps are right-hand rotation (Clockwise when viewed from the driver end). Switch power on and off. Observe shaft rotation. On frame-mounted units, check rotation before coupling pump to motor.
- B. **Single-Phase:** Refer to wiring diagram on motor if rotation must be changed.
- C. **Three-Phase:** Interchange any two power supply leads to change rotation.

### VII. Operation:

- A. Before starting, pump must be primed (free of air and suction pipe full of liquid) and discharge valve partially open. **Caution:** Pumped liquid provides lubrication. If pump is run dry, rotating parts will seize and mechanical seal will be damaged.
- B. Make complete check after unit is run under operating conditions and temperature has stabilized. Check for expansion of piping. Check coupling alignment.
- C. **Do not operate at or near zero flow.** Energy imparted to the liquid is converted into heat. Liquid may flash to vapor. Rotating parts require liquid to prevent scoring or seizing.

### VIII. Maintenance:

- A. Bearings are located in and are part of the motor. For lubrication procedure, refer to manufacturer's instructions.
- B. On frame-mounted units, regrease at 2,000 hours use or 3 months. Use #2 Sodium or Lithium grease and fill until grease comes out of the relief fitting.

### IX. Disassembly:

- A. Turn power off.
- B. Drain system. Flush if necessary.
- C. Remove motor hold-down bolts on close-coupled or disconnect coupling and remove spacer.
- D. Remove casing bolts and pump hold-down bolts.
- E. Remove motor and rotating element from casing.
- F. Unscrew impeller bolt with a socket wrench. **Do not insert screwdriver between impeller vanes to prevent rotation.** It may be necessary to use a strap wrench around the impeller if impacting the socket wrench will not loosen the impeller bolt.
- G. Remove impeller washer.
- H. Insert two pry bars (180° apart) between impeller and seal housing. Pry off impeller.
  - I. Remove seal spring, cupwasher and impeller key.
- J. Remove seal housing, pulling with it the rotating seal parts. (Pry bar slots provided where necessary.)
- K. Place seal housing on flat surface. Press out stationary seal parts.
- L. Remove deflector from shaft on frame-mounted units.
- M. Remove bolts holding bearing cover to frame and remove bearing cover (frame-mount).
- N. Remove lip seals from bearing frame and bearing cover (frame-mount).

- O. Remove shaft and bearings from frame (frame-mount).
- P. Straighten tang in lockwasher. Remove locknut and lockwasher (frame-mount).
- Q. Use bearing puller or arbor press to remove ball bearings (frame-mount).
- R. Remove shaft sleeve if badly scored. Shaft sleeve is bonded to the shaft and must be heated to about 250°F to facilitate removal.
- S. Remove wear ring if excessively worn. Use pry bar and/or vicegrips.

## X. Reassembly:

- A. All parts should be cleaned before assembly.
- B. Refer to parts list to identify required replacement items.
- C. Reassembly is the reverse of the disassembly procedure.
- D. Replace lip seals if worn or damaged (frame-mount).
- E. Replace ball bearings if loose, rough or noisy when rotated (frame-mount).
- F. Check shaft for maximum runout of .005" TIR. Bearing seats and lip seal areas must be smooth and free of scratches or grooves. Replace if necessary (frame-mount).
- G. Shaft sleeve surface must be smooth. Spray both shaft sleeve fit and bore with LOCQUIC PRIMER "T" (Locktite product Item No. 74756). Let parts dry and then apply Loctite #271 on same surfaces. Slide shaft sleeve over shaft, twisting back and forth a couple of times. Wipe off excess. Let cure according to instructions. Purchase Loctite products at Auto Parts or Hardware store.
- H. All mechanical seal components must be in good condition or leakage may result. Replacement of complete seal assembly, whenever seal has been removed, is good standard practice.
- I. If wear ring is being replaced, use no lubricants on the metal-to-metal fit when pressing in the replacement.
- J. If the impeller is removed, as for example to effect a mechanical seal change, this procedure must be followed: Old impeller bolt and impeller gaskets cannot be re-used.
- K. With the stationary and rotary part of the mechanical seal and impeller gasket (hub to sleeve) properly installed, mount the impeller on the shaft but do not install the mechanical seal spring and the retainer as yet. With the impeller bottomed on the shaft sleeve note the distance of the shaft end to the face of the impeller hub on the inlet side. Remove the impeller from the shaft.
- L. Install the mechanical seal spring retainer to the spring. Retainer should snap in place evenly. Install spring/retainer assembly on the shaft and mechanical seal with free-end of spring toward the mechanical seal.
- M. Install key in shaft keyway and mount impeller on shaft with the spring fairly well centered. Push impeller until it bottoms, hold in position and note shaft end to impeller hub face distance. It should match that obtained in step 2. If greater than in step 2, there is a strong possibility that the retainer is pinched between the impeller and sleeve. This is not correct and the process must be repeated until the correct distance is obtained.
- N. Hold the impeller in place and install the impeller gasket (hub to washer) and the previously prepared impeller bolt and washer assembly. Tighten bolt to 35 lb.-ft.

## XI. Trouble-Shooting:

- A. Motor does not start, and no noise or vibration occurs:
  1. Power supply not connected.
  2. Fuses or protection device tripped or defective.
  3. Loose or broken electrical connections.
- B. Motor will not start, but generates noise and vibration:
  1. Motor not wired as directed on diagram.
  2. Shaft locked due to mechanical obstructions in motor or pump.
  3. Low voltage or phase loss on three phase supply.
- C. Pump does not deliver rated capacity:
  1. Pump not filled and primed.
  2. Pump has lost prime due to leaks in suction line.
  3. Direction of rotation incorrect. See **Rotation**.
  4. Head required is higher than that originally specified. (Valve may be partially closed.)
  5. Foot valve clogged.
  6. Suction lift too high.
  7. Suction pipe diameter too small.
- D. Protection trips as unit starts:
  1. Phase loss on three-phase supply.
  2. Protection device may be defective.
  3. Loose or broken electrical connections.
  4. Check motor resistance and insulation to ground.
- E. Protection device trips too often:
  1. Protection may be set to a value lower than motor full load.
  2. Phase loss due to faulty contacts or supply cable.
  3. Liquid is viscous or its specific gravity is too high.
  4. Rubbing occurs between rotating and stationary parts.
- F. Shaft spins with difficulty:
  1. Check for obstructions in the motor or the pump.
  2. Rubbing occurs between rotating and stationary parts.
  3. Check bearings for proper conditions.
- G. Pump vibrates, runs noisily, and flow rate is uneven:
  1. Pump runs beyond rated capacity.
  2. Pump or piping not properly secured.
  3. Suction lift too high.
  4. Suction pipe diameter too small.
  5. Cavitation caused by insufficient liquid supply or excessive suction losses.
  6. Impeller blockage.
- H. When stopped, unit turns slowly in the reverse direction:
  1. Leaks on air locks in suction pipe.
  2. Partial blockage in check valve.
- I. In pressure boosting applications, the unit starts and stops too often:
  1. Pressure switch settings are incorrect.
  2. Tank size may be incorrect.
- J. In pressure boosting applications, the unit does not stop:
  1. Pressure switch maximum setting is higher than was specified.
  2. Direction of rotation incorrect. See **Rotation**.

## SST-C Components

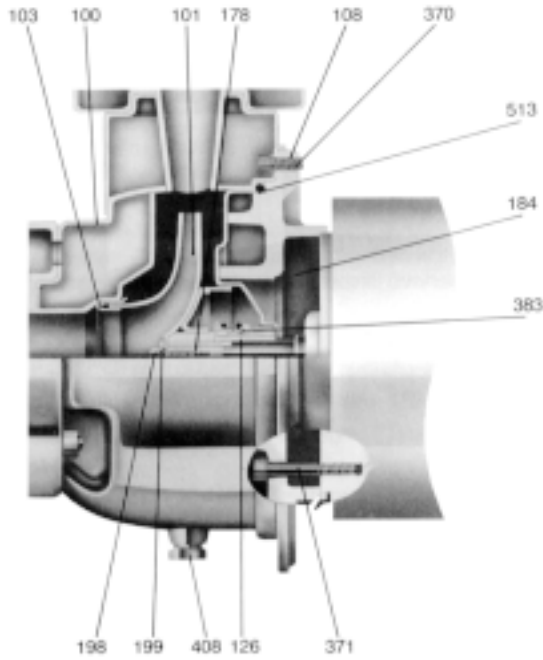

### MATERIALS OF CONSTRUCTION

Item	Description	Material
100	Casing	AISI TYPE 300 Stainless Steel
101	Impeller	
103	Wear Ring	
184	Seal Housing	
126	Shaft Sleeve	
178	Impeller Key	
198	Impeller Bolt	
199	Impeller Washer	
370	Socket Head Cap Screw (Casing to Adapter)	
108	Adapter	
371	Hex Head Cap Screw (Adapter to Motor)	Steel SAE 1200 Series
513	O—Ring	Buna—N
408	Drain Plug — 3/8 NPT	AISI TYPE 304 S/S
383	Mechanical Seal Part No. 10K13	Carbon/Ceramic Buna Elastomers 300 S/S Metal Parts

### MOTOR DATA

Motor Frame	MOTOR HORSEPOWER								Wt. Max. (lbs.)
	3500 RPM				1750 RPM				
	1ø		3ø		1ø		3ø		
	ODP	TEFC	ODP	TEFC	ODP	TEFC	ODP	TEFC	
143	2	—	—	1	—	1	—	1	44
145	3	2	3	2	2	2	2	2	57
182	3	—	5	3	2	2	3	3	76
184	5	3	7½	5	3	3	5	5	92
213	—	5	10	7½	5	5	—	—	144
215	—	—	15	10	—	—	—	—	170
*254S	—	—	20	15	—	—	—	—	253
*256S	—	—	25	20	—	—	—	—	305

\*254 frame with 215JM shaft extension

### OPTIONAL MECHANICAL SEALS

John Crane Type 21 Mechanical Seals						
Item	Part No.	Rotary	Stationary	Elastomers	Metal Parts	Intended Duty
383 Options	10K19	Carbon	Ni-Resist	EPR	316 S.S.	Hi-Temperature
	10K25		Ni-Resist	Viton		Chemical
	10K27		Tungsten Carbide	EPR		Hi-Temperature Mild Abrasive

## SST-F Components

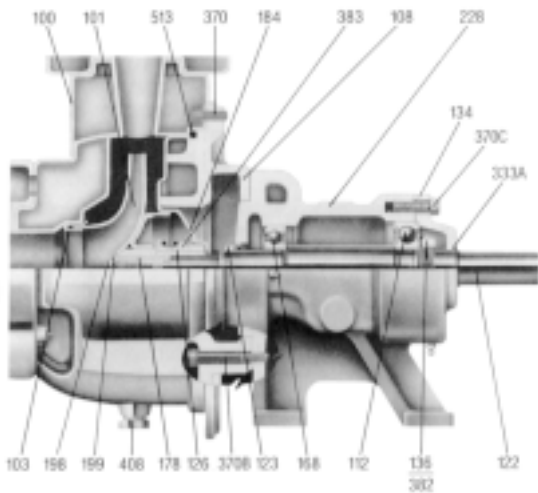

### MATERIALS OF CONSTRUCTION

Item	Description	Material	
Pump End Components	100	Casing	AISI TYPE 300 Stainless Steel
	101	Impeller	
	103	Wear Ring	
	184	Seal Housing	
	126	Shaft Sleeve	
	178	Impeller Key	
	198	Impeller Bolt	
	199	Impeller Washer	
	370	Socket Head Cap Screw	
	408	Drain plug - 3/8 NPT	
513	O-Ring	Buna N	
383	Mechanical Seal Standard Part No. 10K13	Carbon/Ceramic Buna N Elastomers 300 S/S Metal Parts	
Power End Components	108	Adapter	Cast Iron ASTM A48 CL20
	228	Bearing Frame	
	134	Bearing Cover	
	122	Pump Shaft	Steel ASTM A108/ SAE 1200 Series
	168	Ball Bearing (Inboard)	
	112	Ball Bearing (Outboard)	
	136	Locknut, Bearing	
	382	Lock Washer, Bearing	
	370B	Hex Head Cap Screw (Adapter to Bearing Frame)	
	370C	Hex Head Cap Screw (Bearing Frame to Cover)	
333A	Lip Seal	Buna N	
193	Grease Fitting	Steel	
123	V-Ring Deflector	Buna N	

### OPTIONAL MECHANICAL SEALS

John Crane Type 21 Mechanical Seals						
Item	Part No.	Rotary	Stationary	Elastomers	Metal Parts	Intended Duty
383 Options	10K19	Carbon	Ni-Resist	EPR	316 S.S.	Hi-Temperature
	10K25		Ni-Resist	Viton		Chemical
	10K27		Tungsten Carbide	EPR		Hi-Temperature Mild Abrasive