

Note: For S-Group power frame individual parts see S-Group Power Frame repair parts page.

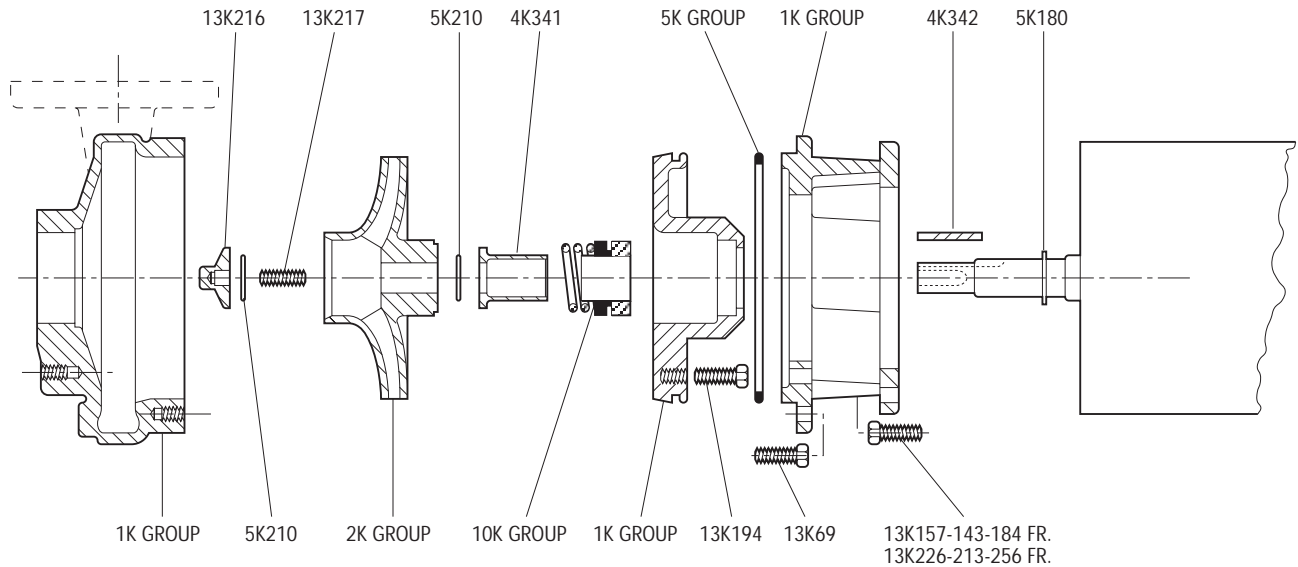

IMPELLERS

Part No.	Part Name	Material	Pattern No.
1K212	Casing 1½ x 2-6	316 SS	59184
1K213	Casing 2 x 3-7	316 SS	59185
1K214	Casing 1½ x 2-8	316 SS	59186
1K215	Seal housing 1½ x 2-6	316 SS	59181
1K216	Seal housing 2 x 3-7	316 SS	59182
1K217	Seal housing 1½ x 2-8	316 SS	59183
1K220	Motor adapter 1½ x 2-6 143-184 FR	C.I.	59176
1K221	Motor adapter 1½ x 2-6 213-215 FR	C.I.	59177
1K222	Motor adapter 2 x 3-7 143-184 FR	C.I.	59178
1K223	Motor adapter 2 x 3-7 213-254 FR	C.I.	59179
1K224	Motor adapter 1½ x 2-8 143-184 FR	C.I.	59180
1K225	Motor adapter 1½ x 2-8 213-256 FR	C.I.	59187
4K341	Shaft sleeve	316 SS	59191
4K342	Impeller key	Steel	
5K206	O-ring – 2 x 3-7	Viton	
5K193	O-ring – 1½ x 2-6	EPR	
5K207	O-ring – 1½ x 2-6	Viton	
5K192	O-ring – 1½ x 2-6	EPR	
5K205	O-ring – 1½ x 2-8	Viton	
5K194	O-ring – 1½ x 2-8	EPR	
5K210	O-ring – impeller	Viton	
5K195	O-ring – shaft deflector	EPR	
5K180	O-ring – shaft deflector	BUNA	
10K27	Mechanical seal – standard duty and high temperature	Carbon/sil car – 316 SS/viton	
10K19	Mechanical seal – standard duty	Carbon/sil car – 316 SS/EPR	
10K64	Mechanical seal – severe duty	Sil car/sil car – 316 SS/Viton	
13K157	Hex cap screw – adapter to motor 143-184 FR adapter to seal housing and casing – all	304 SS	59192
13K216	Impeller nut	316 SS	
13K217	Impeller stud	Steel	
13K226	Hex cap screw – adapter to motor – 213-256 FR	304 SS	

Group	Part No.	Diameter – HP/Enclosure
1½ x 2-6	2K297	6" 5 HP ODP – 1.15 SF and 5 HP TEFC – 1.25 SF
	2K298	5¾" 5 HP TEFC – 1.0 SF
	2K299	5¼" 3 HP ODP – 1.15 SF and 3 HP TEFC – 1.25 SF
	2K300	4¾" 3 HP TEFC – 1.0 SF
	2K301	7" 20 HP ODP and 20 HP TEFC – all
2 x 3-7	2K302	6¾" 15 HP ODP – 1.15 SF and 15 HP TEFC – 1.25 SF
	2K303	6¾" 15HP TEFC – 1.0 SF
	2K304	5½" 10 HP ODP – 1.15 SF and 10 HP TEFC – 1.25 SF
	2K305	5½" 10 HP TEFC – 1.0 SF
	2K306	5½" 7½ HP ODP – 1.15 SF and 7½ HP TEFC – 1.25 SF
	2K307	5½" 7½ HP TEFC – 1.0 SF
	2K308	4¾" 5 HP ODP – 1.15 SF and 5 HP TEFC 1.25 SF
	2K309	4¾" 5 HP TEFC – 1.0 SF
	2K310	3¾" 3 HP ODP – 1.15 SF and 3 HP TEFC 1.25 SF
	1½ x 2-8	2K311
2K312		7¾" 20 HP ODP 1.15 SF
2K313		7½" 15 HP TEFC 1.25 SF and 20 HP TEFC 1.0 SF
2K314		7¼" 15 HP ODP 1.15 SF
2K315		7" 15 HP TEFC 1.0 SF
2K316		6½" 10 HP TEFC 1.25 SF
2K317		6¼" 10 HP ODP 1.15 SF
2K318		6" 7 ½ HP TEFC 1.25 SF and 10 HP TEFC 1.0 SF
2K319		5½" 7½ HP ODP 1.15 SF
2K320		5½" 7½ HP TEFC 1.0 SF
2K321		5¼" 5 HP ODP 1.15 SF and 5 HP TEFC 1.25 SF

Goulds Pumps and the ITT Engineered Blocks Symbol are registered trademarks and tradenames of ITT Industries.