

MODEL

3656/3756 S, M & L- Group

Effective September, 2003



Pump End Parts For Close-Coupled or Frame Mounted Configuration

3656/3756
S-Group

Note: For S-Group power frame individual parts see S-Group Power Frame repair parts page.

Mechanical Seal Arrangement

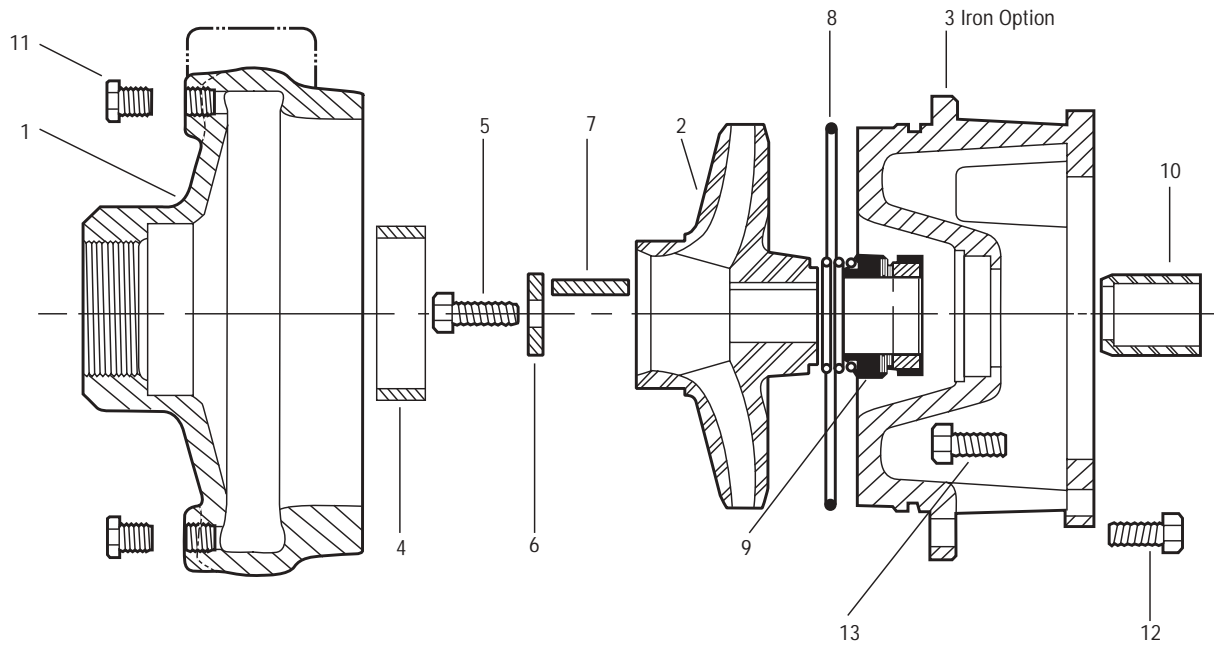

NOTE:

Check pump and motor nameplates before ordering impellers. Select proper part by determining pump size, material, motor type and HP. Pump size 1½ x 2-8 after October 1987 will have nameplate index - 1 (19; 5BF11135-1, with 6¾" impeller) indicating new impeller sizes, consult curves with price sheets. Prior to October 1987, order old style impeller from list on back. Consult factory when ordering repair parts for pumps having a factory order number as the index number.

- ▼ All bronze models produced after December, 1987 have cast iron motor adapters and bronze seal housings. When ordering motor adapters for repairs, order "K" number listed by pump size, construction and motor frame size. These motor adapter assemblies are interchangeable with old style one piece adapter.

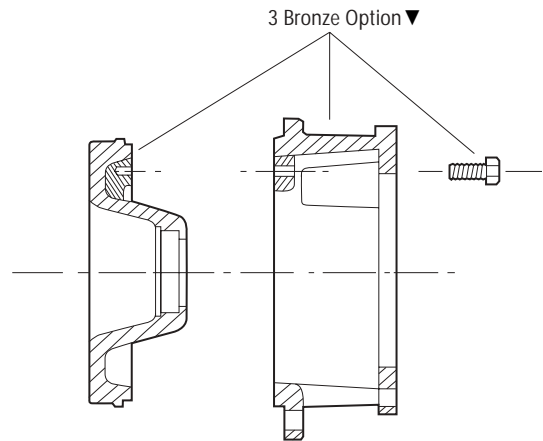

Packed Box Arrangement 140JP - 180JP & 210 TCZ (west coast fit)

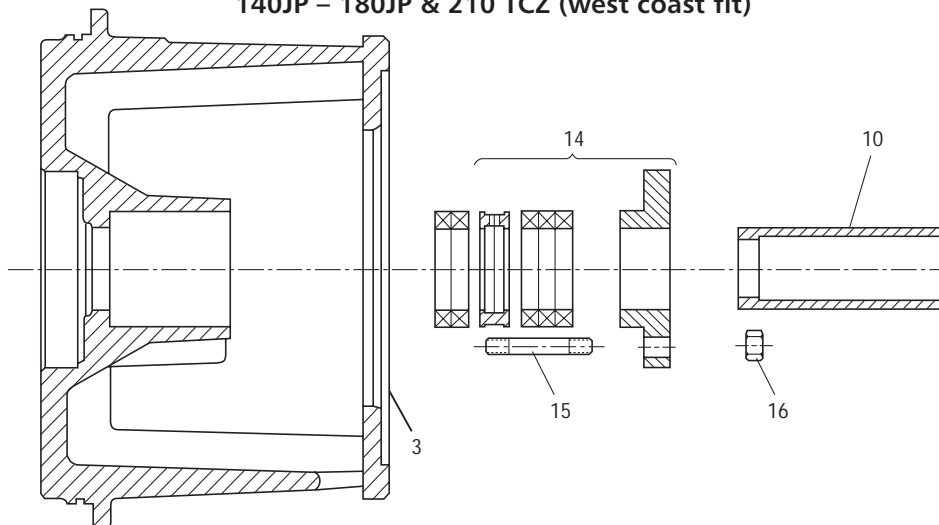

Pump End Parts For Close-Coupled with 140JM, 180JM, 210JM (Mechanical Seal) 140JP, 180JP, 210TCZ (Packed Box)

3656/3756
S-Group

Item No.	Part Description	Material	Repair Part No.									
			22BF	9BF	3AI/BF/AB	3AIH/BFH/ABH	5AI/BF/AB	4AI/BF/AB	6AI/BF/AB			
			1 x 2-7	1 x 2-8	1½ x 2-6	1½ x 2-6H	1½ x 2-8	2½ x 3-7	3 x 4-7			
1	Casing	Cast Iron	1K365	1K612	1K98		1K102	1K100	1K128			
		Bronze			1K99		1K103	1K101	1K129			
2	Impeller	Cast iron			2K124 (4.75)	2K154 (5.62)	2K344 (5.75)	2K214 (3.88)	2K741 (4.12)	2K233 (4.69)		
					2K122 (5.12)	2K152 (5.94)	2K768 (6.12)	2K212 (4.12)	2K740 (4.75)	2K232 (5.12)		
					2K120 (5.62)		2K343 (6.25)	2K210 (4.44)	2K739 (4.94)	2K230 (5.50)		
					2K118 (5.94)		2K342 (6.75)	2K208 (4.62)	2K738 (5.25)	2K229 (6.38)		
							2K341 (7.00)	2K134 (5.06)	2K737 (5.44)	2K324 (7.06)		
							2K340 (7.62)	2K132 (5.38)	2K736 (5.62)			
							2K339 (7.75)	2K130 (5.50)	2K735 (5.88)			
							2K338 (8.06)	2K128 (5.88)	2K734 (6.38)			
								2K156 (6.38)	2K733 (6.75)			
								2K126 (6.75)	2K732 (7.06)			
				Sil-Brass	2K815 (3.81)	2K767 (5.12)	2K125 (4.75)	2K155 (5.62)	2K769 (6.12)	2K215 (3.88)	2K751 (4.12)	2K238 (4.69)
					2K814 (4.06)	2K765 (5.38)	2K123 (5.12)	2K153 (5.94)	2K351 (5.75)	2K213 (4.12)	2K750 (4.75)	2K237 (5.12)
					2K813 (4.38)	2K763 (6.19)	2K121 (5.62)		2K350 (6.25)	2K211 (4.44)	2K749 (4.94)	2K235 (5.50)
					2K812 (4.56)	2K761 (6.50)	2K119 (5.94)		2K349 (6.75)	2K208 (4.62)	2K747 (5.44)	2K234 (6.38)
					2K811 (4.81)	2K759 (7.00)			2K348 (7.00)	2K135 (5.06)	2K746 (5.62)	2K325 (7.06)
					2K810 (5.06)	2K757 (7.31)			2K347 (7.62)	2K133 (5.38)	2K745 (5.88)	
					2K809 (5.50)	2K755 (7.62)			2K346 (7.75)	2K131 (5.50)	2K744 (6.38)	
					2K808 (5.75)	2K753 (8.06)			2K345 (8.06)	2K129 (5.88)	2K743 (6.75)	
					2K807 (6.00)					2K157 (6.38)	2K742 (7.06)	
					2K806 (6.44)					2K127 (6.75)		
		2K805 (6.75)										
3	Motor adapter – seal 140-180JM and frame mounted (210JM)	Cast iron	1K118	1K114	1K110	1K110	1K114	1K118	1K118			
		Sil-Brass			1K111	1K111	1K115	1K119	1K119			
	Motor adapter – packing (140-180J) and frame mounted (210TCZ)	Cast iron	1K120	1K116	1K112	1K112	1K116	1K120	1K120			
		Sil-Brass			1K113	1K113	1K117	1K121	1K121			
		Cast iron	1K369	1K371	1K367	1K367	1K371	1K369	1K369			
4	Casing wear ring	Cast iron	4K67					4K69†	4K263			
		Bronze	4K68					4K70†	4K264			
5	Impeller bolt		13K43									
6	Impeller washer	AISI 303SS	13L39									
7	Impeller key		4K11									
8	Casing o-ring	BUNA	5K4	5K74	5K73		5K74	5K4				
		EPR	5K193	5K192	5K194		5K192	5K193				
		Viton	5K206	5K205	5K207		5K205	5K206				
9	Seal assembly	Carbon/ceramic BUNA	10K13									
		Carbon/sil-carb. EPR	10K19									
		Carbon/sil-carb. viton	10K27									
		Sil-carb./sil-carb./viton	10K64									
10	Shaft sleeve – mechanical seal	300SS	4K66									
	Shaft sleeve – packed box	300SS	4K473									
11	¼" pipe plug (casing)	Zinc Plated Steel	6K2 (Qty. 4)									
		Bronze	6K42 (Qty. 4)									
12	Hex head screw (casing)	Zinc Plated Steel	13K69 (Qty. 4)									
13	Hex head screw (motor adapter)	(140 – 180)	13K69 (Qty. 8)									
		(210)	13K937									
14	Packed box kit includes – gland Packing & lantern	316SS	15K16									
		Teflon	15K16									
15	Gland stud (qty. 2)	300SS	13K295									
16	Gland nut (qty. 2)	300SS	13K262									

NOTES: Casing includes plugs. Impeller bolt and shaft sleeve must be removed. When replacing, bond and seal shaft sleeve and impeller bolt to shaft with Loctite AL27121.
 *2½ x 3-7 pumps built after March 1, 1996 are supplied with new style impeller. Old style impeller numbers are listed for reference only. Use NEW numbers for repairs.
 †2½ x 3-7 use two casing wear rings, same front and back.
 ‡1750 RPM only.

Pump End Parts For Close-Coupled or Frame Mounted Configuration

3656/3756
M & L-Group

Note: For M & L-Group power frame individual parts see M & L-Group Power Frame repair parts page.

Mechanical Seal Arrangement

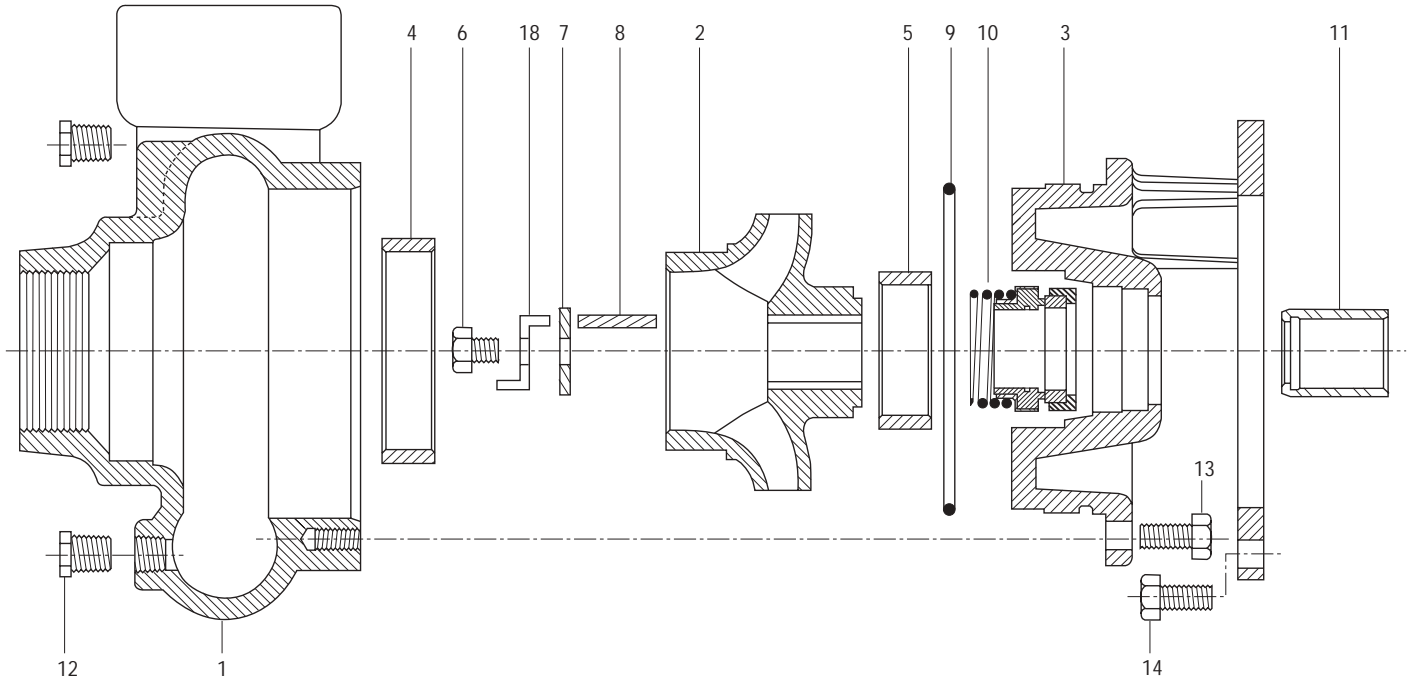

Packed Box Arrangement 250JP – 360 TCZ, Frame Mount and SAE Drive 250JP – 445TCZ, Close-Coupled

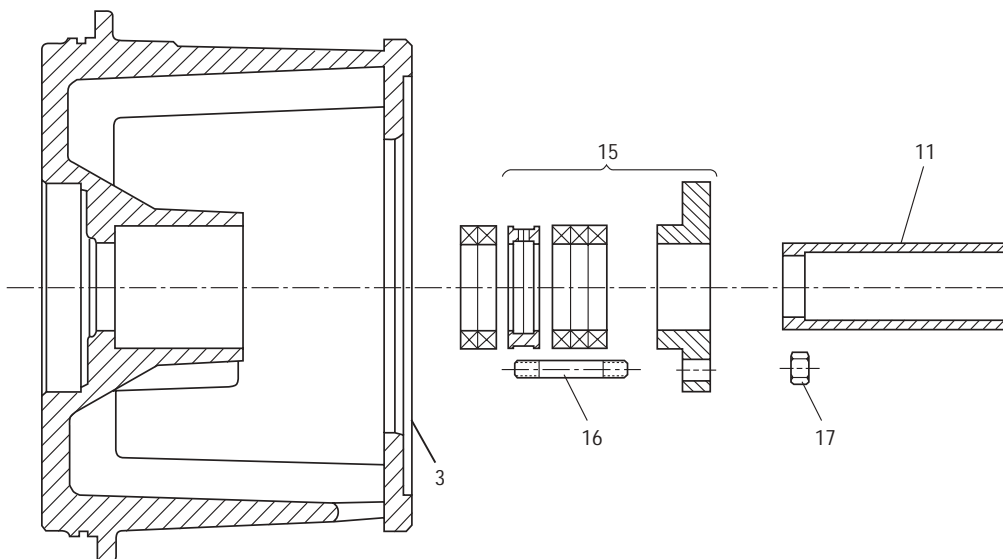

Pump End Parts For Close-Coupled with 140JM, 180JM, 210JM (Mechanical Seal), 140JP, 180JP, 210TCZ (Packed Box)

3656/3756
M-Group

(All pumps in this section have a 7/8" Dia. Impeller Hub Bore)

Item No.	Part Description	Material	Repair Part No.							
			7 AI/BF	16 AI/BF	10 AI/BF	8 AI/BF	11 AI/BF	12 AI/BF	21BF	
			2½ x 3 – 8	3 x 4 – 8	4 x 5 – 8	1½ x 2 – 10	2½ x 3 – 10	3 x 4 – 10	2½ x 3 – 9	
1	Casing	Cast Iron	1K130	1K316	1K238	1K132	1K236	1K237	1K236	
2	Impeller	Cast Iron	8½/16 2K573	8½/16 2K673	8½/16 2K589	10½/16 2K609	10½/16 2K665	10½/16 2K633		
			7½/16 2K575	7½/16 2K675	7½/16 2K591	9½/16 2K611	9½/16 2K667	9½/16 2K635		
			7½/16 2K577	6¾ 2K677	7¼ 2K593	8¾ 2K613	9¾ 2K669	9 2K637		
			7½/16 2K579	6¾ 2K679	7½ 2K595	7¾ 2K615	9 2K671	8½/16 2K639		
			6½/16 2K581	5½/16 2K681	7¼ 2K597	7½/16 2K617	8½/16 2K623	8½/16 2K641		
			6½ 2K583	5½ 2K683	7 2K599	7¼ 2K619	8¼ 2K625	7½/16 2K643		
			6¾ 2K585	5½ 2K685	6¾ 2K601	7 2K621	8 2K627			
			6¾/16 2K587	4¾ 2K687	6½ 2K603		7¾ 2K629			
					6½/16 2K605		7½/32 2K631			
					5¾ 2K607					
				8½/16 2K574	8½/16 2K674	8½/16 2K590	10½/16 2K610	10½/16 2K666	10½/16 2K634	10½/16 2K1010
				7½/16 2K576	7½/16 2K676	7½/16 2K592	9½/16 2K612	9¾ 2K668	9¾ 2K636	9¾ 2K1011
				7½/16 2K578	6¾ 2K678	7¼ 2K594	8¾ 2K614	9¾ 2K670	9 2K638	9½ 2K1012
				7½/16 2K580	6¾ 2K680	7½ 2K596	7¾ 2K616	9 2K672	8½/16 2K640	9¼ 2K1013
				6½/16 2K582	5½/16 2K682	7¼ 2K598	7½/16 2K618	8½/16 2K624	8½/16 2K642	8½/16 2K1014
				6½ 2K584	5½ 2K684	7 2K600	7¼ 2K620	8¼ 2K626	7½/16 2K644	8½/16 2K1015
				6¾ 2K586	5½ 2K686	6¾ 2K602	7 2K622	8 2K628		8½/16 2K1016
				6¾/16 2K588	4¾ 2K688	6½ 2K604		7¾ 2K630		8 2K1017
						6½/16 2K606		7½ 2K632		7½/16 2K1018
						5¾ 2K608				
3	Motor adapter 140-180JM	Cast Iron	1K114			1K319				
	-Seal 210JM		1K116			1K320				
	Motor adapter 140-180JP		1K371			1K381				
	-Packing 210TCZ		1K372			-				
4	Front wear ring	Cast Iron	4K265	4K350	4K352	4K267	4K265	4K350		
		Bronze	4K266	4K351	4K353	4K268	4K266	4K351	4K266	
5	Back wear ring	Cast Iron	-	-	-	-	-	-		
		Bronze	-	-	-	-	-	-		
6	Impeller bolt		13K43							
7	Impeller washer	AISI 303 SS	13L39							
8	Square key		4K11							
9	O-ring	BUNA	5K74			5K155				
		Viton	5K205			5K208				
		EPR	5K192			5K318				
10	Seal assembly Carbon/ceramic	BUNA	10K13							
	Carbon/Sil-carb.	EPR	10K19							
	Carbon/Sil-carb.	Viton	10K27							
	Sil-carb./Sil-carb.	Viton	10K64							
11	Shaft sleeve	300 SS	4K66							
	Seal packing		4K473							
12	¾" NPT plug		6K2		6K3					
13	Casing HD screw	Zinc Plated	13K69							
14	Motor screw	Steel	13K69 (140 & 180 JM/JP) and 13K102 (250 JM/JP & Frame)							
	Loctite #271		AL27121							
15	Packed box kit includes:									
	Gland	316 SS								
	Packing & lantern ring	Teflon	15K16							
16	Stud, gland (Qty. 2)	300 SS	13K295							
17	Hex nut, gland (Qty. 2)	300 SS	13K262							

Pump End Parts For Close-Coupled With 250JM-360TCZ (Mechanical Seal), 210JP-445TCZ (Packed Box) And All Frame Mounted Configuration

3656/3756
M-Group

Note: For M & L-Group power frame individual parts, see M & L-Group Power Frame repair parts page.

Item No.	Part Description	Material	Repair Part No.										
			7 AI/BF	16 AI/BF	10 AI/BF	8 AI/BF	11 AI/BF	12 AI/BF	17BF	21BF			
			2 1/2 x 3-8	3 x 4-8	4 x 5-8	1 1/2 x 2-10	2 1/2 x 3-10	3 x 4-10	4 x 6-10	2 1/2 x 3-9			
1	Casing	Cast Iron	1K130	1K316	1K238	1K132	1K236	1K237	1K351	1K236			
2	Impeller	Cast Iron	7 ¹⁵ / ₁₆ 2K168	8 ¹ / ₁₆ 2K689	8 ¹ / ₁₆ 2K645	9 ¹ / ₁₆ 2K176	10 ¹ / ₁₆ 2K370	10 ¹ / ₁₆ 2K395					
			7 ³ / ₁₆ 2K170	7 ¹ / ₁₆ 2K691	7 ⁷ / ₈ 2K647	8 ³ / ₈ 2K178	9 ⁷ / ₈ 2K371	9 ⁹ / ₁₆ 2K396					
			6 ¹³ / ₁₆ 2K172	6 ³ / ₄ 2K693	7 ³ / ₄ 2K649	7 ³ / ₄ 2K180	9 ⁵ / ₈ 2K372	9 2K397					
			6 ³ / ₁₆ 2K174	6 ⁵ / ₈ 2K695	7 ¹ / ₂ 2K651	7 2K182	9 2K373	8 ⁵ / ₈ 2K398					
			6 ³ / ₈ 2K480	5 ¹⁵ / ₁₆ 2K697	7 ¹ / ₄ 2K653	10 ¹ / ₁₆ 2K490	8 ⁵ / ₈ 2K374	8 ¹ / ₈ 2K399					
			7 ¹ / ₁₆ 2K482	5 ¹ / ₂ 2K699	7 2K655	7 ⁵ / ₁₆ 2K492	8 ¹ / ₄ 2K375	7 ⁵ / ₈ 2K400					
				5 ¹ / ₈ 2K701	6 ³ / ₄ 2K657	7 ¹ / ₄ 2K468	8 2K376						
			4 ⁵ / ₈ 2K703	6 ¹ / ₂ 2K659		7 ⁵ / ₈ 2K377							
				6 ¹ / ₁₆ 2K661		7 ¹ / ₈ 2K378							
				5 ³ / ₄ 2K663									
				7 ¹⁵ / ₁₆ 2K169	8 ¹ / ₁₆ 2K690	8 ¹ / ₁₆ 2K646	9 ¹ / ₁₆ 2K177	10 ¹ / ₁₆ 2K379	10 ¹ / ₁₆ 2K401	10 ¹ / ₁₆ 2K816	10 ¹ / ₁₆ 2K1001		
				7 ³ / ₁₆ 2K171	7 ¹ / ₁₆ 2K692	7 ⁷ / ₈ 2K648	8 ³ / ₈ 2K179	9 ⁷ / ₈ 2K380	9 ⁹ / ₁₆ 2K402	9 ¹ / ₈ 2K818	9 ⁷ / ₈ 2K1002		
				6 ¹³ / ₁₆ 2K173	6 ³ / ₄ 2K694	7 ³ / ₄ 2K650	7 ³ / ₄ 2K181	9 ⁵ / ₈ 2K381	9 2K403	8 ¹¹ / ₁₆ 2K820	9 ¹ / ₄ 2K1003		
				6 ³ / ₁₆ 2K175	6 ⁵ / ₈ 2K696	7 ¹ / ₂ 2K652	7 2K183	9 2K382	8 ⁵ / ₈ 2K404	8 ¹¹ / ₁₆ 2K822	9 ¹ / ₄ 2K1004		
				6 ³ / ₈ 2K481	5 ¹⁵ / ₁₆ 2K698	7 ¹ / ₄ 2K654	10 ¹ / ₁₆ 2K491	8 ⁵ / ₈ 2K383	8 ¹ / ₈ 2K405	8 ¹ / ₈ 2K824	8 ¹⁵ / ₁₆ 2K1005		
				7 ¹ / ₁₆ 2K483	5 ¹ / ₂ 2K700	7 2K656	7 ⁵ / ₁₆ 2K493	8 ¹ / ₄ 2K384	7 ⁵ / ₈ 2K406	7 ³ / ₄ 2K826	8 ¹ / ₂ 2K1006		
					5 ¹ / ₈ 2K702	6 ³ / ₄ 2K658	7 ¹ / ₄ 2K469	8 2K385	9 ¹ / ₈ * 2K831		8 ¹ / ₁₆ 2K1007		
					4 ⁵ / ₈ 2K704	6 ¹ / ₂ 2K660		7 ⁵ / ₈ 2K386	8 ³ / ₄ * 2K832		8 2K1008		
						6 ¹ / ₁₆ 2K662		7 ¹ / ₈ 2K387	8 ¹ / ₁₆ * 2K833		7 ¹ / ₁₆ 2K1009		
						5 ³ / ₄ 2K664			8 ¹ / ₈ * 2K834				
							7 ³ / ₄ * 2K835						
							7 ⁵ / ₈ * 2K836						
							7 ¹ / ₄ * 2K837						
							7 ¹ / ₁₆ * 2K838						
							6 ³ / ₄ * 2K839						
3	Motor adapter – seal 210TCZ-250JM & frame mounted 280JM-360TCZ	Cast Iron	1K136	1K317	1K317	1K138							
	1K242		1K318	1K318	1K243								
	1K357		1K358	1K358	1K355								
	1K359		1K360	1K360		1K356		–	1K356				
4	Front wear ring	Cast Iron	4K265	4K350	4K352	4K267	4K265	4K350	–	–			
		Bronze	4K266	4K351	4K353	4K268	4K266	4K351	4K363	4K265			
5	Back wear ring	Cast Iron	4K265	4K350	4K350	4K265	4K265	–	–	–			
		Bronze	4K266	4K351	4K351	4K266	4K266	–	4K351	4K265			
6	Impeller bolt		13K155										
7	Impeller washer	AISI 303 SS	13K241										
8	Square key		4K261										
9	O-ring	BUNA	5K74			5K155							
		Viton	5K205			5K208							
		EPR	5K192			5K318							
10	Seal assembly Carbon/ceramic	BUNA	10K16										
	Carbon/Sil-carb.	EPR	10K20										
	Carbon/Sil-carb.	Viton	10K65										
	Sil-carb./Sil-carb.	Viton	10K45										
11	Shaft sleeve, mech. seal	SS	4K262										
	Shaft sleeve, packed box	SS	4K455										
12	3/8" NPT plug (Qty. 2)		6K2			6K3							
13	Casing HD screw (Qty. 8)	Zinc Plated	13K69										
14	Motor screw (Qty. 4)	Steel	13K102 (250 JM/JP & frame mounted)						13K247 (280 JM/JP & larger)				
	Loctite #271		AL27121										
15	Packed box kit includes: Gland	316SS											
	Packing & lantern ring	Teflon	15K3										
16	Stud, gland (Qty. 2)	300 SS	13K291										
17	Hex nut, gland (Qty. 2)	300 SS	13K292										

* 3500 RPM units

Pump End Parts For Close-Coupled With 250JM-360TCZ (Mechanical Seal), 210JP-445TCZ (Packed Box) And All Frame Mounted Configuration

3656/3756
M-Group

Note: For M & L-Group power frame individual parts, see M & L-Group Power Frame repair parts page.

Item No.	Part Description	Material	Repair Part No.		
			13 AI/BF	14 AI/BF	15 AI/BF
			2 1/2 x 3-13	3 x 4-13	4 x 6-13
			M-Group	M-Group	M-Group
1	Casing	Cast Iron	1K239	1K240	1K479
2	Impeller	Cast Iron	13 1/16 2K407	13 1/16 2K419	13 1/16 2K979
			12 3/4 2K408	12 5/16 2K420	12 7/8 2K443
			11 7/8 2K409	12 5/16 2K421	12 1/2 2K444
			11 3/8 2K410	12 2K422	12 1/4 2K445
			9 7/8 2K411	11 3/4 2K423	11 7/8 2K446
			9 3/8 2K412	11 5/16 2K424	11 3/8 2K447
				10 1/4 2K425	11 1/16 2K448
				10 7/8 2K426	10 7/8 2K449
				9 1/8 2K427	10 1/2 2K450
				8 1 1/16 2K428	10 1/4 2K451
			8 2K429	9 7/8 2K452	
			7 7/16 2K430	9 3/8 2K453	
			13 1/16 2K413	13 1/16 2K431	13 1/16 2K980
			12 3/4 2K414	12 5/16 2K432	12 7/8 2K454
			11 7/8 2K415	12 5/16 2K433	12 1/2 2K455
			11 3/8 2K416	12 2K434	12 1/4 2K456
			9 7/8 2K417	11 3/4 2K435	11 7/8 2K457
			9 3/8 2K418	11 5/16 2K436	11 3/8 2K458
				10 3/4 2K437	11 1/16 2K459
				10 7/8 2K438	10 7/8 2K460
		9 7/8 2K439	10 1/2 2K461		
		8 1 1/16 2K440	10 1/4 2K462		
		8 2K441	9 7/8 2K463		
		7 7/16 2K442	9 3/8 2K464		
3	Motor adapter – seal 210TCZ-250JM and frame mounted	Cast Iron	1K244		
	280JM-360TCZ		1K245		
	Motor adapter – packing 210JP-250JP and frame mounted		1K361		
	280JP-360TCZ		1K362		
4	Front wear ring	Cast Iron	4K265	4K350	4K362
		Bronze	4K266	4K351	4K363
5	Back wear ring	Cast Iron	4K350	4K350	4K350
		Bronze	4K351	4K351	4K351
6	Impeller bolt	AISI 303 SS	13K155		
7	Impeller washer		13K241		
8	Square key		4K261		
9	O-ring		BUNA	5K199	
		Viton	5K209		
10	Seal assembly Carbon/ceramic	BUNA	10K16		
	Carbon/Sil-carb.	EPR	10K20		
	Carbon/sil-carb.	Viton	10K65		
	Sil-carb./sil-carb.	Viton	10K45		
11	Shaft sleeve, mech. seal	SS	4K262		
	Shaft sleeve, packed box	SS	4K455		
12	3/8" NPT plug (Qty. 2)	Zinc Plated Steel	6K3		
13	Casing HD screw (Qty. 8)		13K102		
14	Motor screw (Qty. 4)		13K102 (250JM/250JP and frame mounted) 13K247 (280JM/JP and larger)		
	Loctite #271		AL27121		
15	Packed box kit includes: Gland	316SS	15K3		
	Packing & lantern ring	Teflon			
16	Stud, gland (Qty. 2)	300SS	13K291		
17	Hex nut, gland (Qty. 2)	300SS	13K292		

Pump End Parts For Close-Coupled With 250JM-360TCZ (Mechanical Seal), 210JP-445TCZ (Packed Box) And All Frame Mounted Configuration

3656/3756 L-Group

Note: For M & L-Group power frame individual parts, see M & L-Group Power Frame repair parts page.

Item No.	Part Description	Material	Repair Part No.			
			18BF	18BF	19 AI/BF	20BF
			6 x 8-13	6 x 8-13	8 x 10-13	4 x 6-16
			M-Group		L-Group	
1	Casing	Cast Iron	1K352	1K352	1K353	1K354
2	Impeller	Sil-Brass	1180 RPM			
			9 ¹ / ₂ 2K851		9 ¹³ / ₁₆ 2K897	
			10 2K850		10 ⁷ / ₈ 2K896	
			10 ¹ / ₂ 2K849		11 ¹ / ₄ 2K895	
			10 ⁷ / ₈ 2K848		11 ¹¹ / ₁₆ 2K894	
			11 ¹ / ₈ 2K847		11 ¹⁵ / ₁₆ 2K893	
			11 ³ / ₈ 2K846		12 ³ / ₈ 2K892	
			11 ⁵ / ₈ 2K889		12 ³ / ₄ 2K891	
			12 ⁵ / ₁₆ 2K888		13 2K890	
			12 ¹ / ₂ 2K887			
			13 2K886			
			1750 RPM			
			11 ⁵ / ₈ 2K846	13 2K842	13 2K860	16 2K873
			11 ¹ / ₈ 2K847	12 ¹ / ₂ 2K843	12 ³ / ₄ 2K861	15 ⁵ / ₈ 2K874
			10 ⁷ / ₈ 2K848	12 ⁵ / ₁₆ 2K844	12 ³ / ₈ 2K862	15 ³ / ₁₆ 2K875
			10 ¹ / ₂ 2K849	11 ⁷ / ₈ 2K845	11 ¹⁵ / ₁₆ 2K863	14 ¹ / ₂ 2K876
			10 2K850	11 ⁵ / ₈ 2K880	11 ¹¹ / ₁₆ 2K864	13 ³ / ₄ 2K877
			9 ¹ / ₂ 2K851	11 ¹ / ₈ 2K881	11 ¹ / ₄ 2K865	
				10 ⁷ / ₈ 2K882	10 ⁷ / ₈ 2K866	
				10 ¹ / ₂ 2K883	9 ¹³ / ₁₆ 2K867	
	10 2K884					
	9 ¹ / ₂ 2K885					
3	Motor adapter – Mech. seal 210JP-250JP 280-360TCZ 360JP-400TCZ 440TCZ	Frame Mounted	Cast Iron	–	1K377	1K379
				1K377		
				1K378	1K378	1K380
	Motor adapter – Packed box 210JP-250JP 280-360TCZ 360JP-400TCZ 440TCZ	Frame Mounted	Cast Iron	–	1K480 & 1K412	–
				–	1K373	1K375
				1K373	1K374	1K376
4	Front wear ring	Bronze	4K475	1K480 & 1K412	–	
5	Back wear ring	Bronze	4K474	4K476	4K477	
6	Impeller bolt			13K155		
7	Impeller washer	AISI 303 SS		13K290		
8	Square key			4K460		
9	O-ring	BUNA	5K199		5K298	
		Viton	5K209		5K299	
10	Seal assembly (Stat / Rot) Ceramic/carbon	BUNA	10K84			
	Sil-carb./Carbon	Viton	10K112			
	Sil-carb./sil-carb.	Viton	10K144			
11	Shaft sleeve, mech. seal 210-320	300 SS	–	4K457		
	360-440TCZ		4K457			
	–		4K459			
	Shaft sleeve, packed box 210-320		–	4K456		
360-440TCZ		4K456				
12	Plug, casing (Qty. 2)		6K3			
13	Bolt, casing (Qty. 8)		13K69			
14	Bolt, motor (Qty. 4) Frame Mounted	Zinc Plated Steel		13K102 (Qty. 4)		
	210-250		13K247 (Qty. 4)			
	280-405TCZ		13K247 (Qty. 8)			
	445TCZ					
15	Packed box kit includes: Gland	316SS	15K4			
	Packing & lantern ring	Teflon				
16	Stud, gland (Qty. 2)	300SS	13K291			
17	Hex nut, gland (Qty. 2)	300SS	13K292			